

**LINCOLN CITY PUBLIC WORKS DEPARTMENT  
DESIGN STANDARDS**

801 SW Hwy 101 – PO Box 50, Lincoln City, OR 97367

Phone: (541) 996-2154 (City Hall General Information)

(541) 996-1013 (Public Works Administration and Inspection Requests)

---

**Table of Contents**

GENERAL PERMIT CONDITIONS.....	4
CHAPTER 1- WATER.....	6
General Requirements .....	6
Material and Construction Standards.....	8
Water Mains.....	8
Bell Restraint Harness .....	8
Water Valves .....	9
Air Release Valves .....	9
Valve Boxes.....	9
Fire Hydrants .....	9
Services 2-inches and smaller.....	9
Tracer Wire.....	10
Testing Requirements .....	11
CHAPTER 2- SANITARY SEWER.....	13
General Requirements .....	13
Material and Construction Standards.....	14
Sanitary Sewer Mains.....	14
Sanitary Sewer Lateral Taps and Saddles.....	15
Sanitary Sewer Manholes .....	15
Tracer Wire.....	15
Testing Requirements .....	16
CHAPTER 3- STORMWATER SYSTEM.....	17
General Permit Requirements.....	17
Erosion Control.....	18
Design Storm .....	18
Design Methodology .....	18
Detention .....	19
Outflow Control.....	19
Water Quality.....	19
Material and Construction Standards.....	20
Stormwater Drain Pipeline .....	20
Catch Basins and Inlets.....	20
Outfall(s)/Discharge(s) .....	21
Tracer Wire.....	21
Testing Requirements .....	22
CHAPTER 4 - LOW PRESSURE SANITARY PUMP SYSTEMS.....	23
CHAPTER 5 - STREETS.....	25
General Permit Requirements.....	25
Design Standards .....	26
Street Profile .....	26
Centerline Radius.....	26
Right of Way.....	26
Subgrade .....	27

**LINCOLN CITY PUBLIC WORKS DEPARTMENT  
DESIGN STANDARDS**

801 SW Hwy 101 – PO Box 50, Lincoln City, OR 97367

Phone: (541) 996-2154 (City Hall General Information)

(541) 996-1013 (Public Works Administration and Inspection Requests)

---

Roadway Section .....	27
Asphalt Concrete Paving (ACP).....	27
Cross Slope .....	27
Street Cross Section.....	27
Curb Returns.....	28
Curb and Gutter .....	28
Side Slopes.....	28
Sight Distance.....	28
Pavement Markings .....	28
Accessible Ramps.....	29
Street Signs .....	29
Residential Driveways.....	29
Sidewalks .....	30

**LINCOLN CITY PUBLIC WORKS DEPARTMENT  
DESIGN STANDARDS**

801 SW Hwy 101 – PO Box 50, Lincoln City, OR 97367

Phone: (541) 996-2154 (City Hall General Information)

(541) 996-1013 (Public Works Administration and Inspection Requests)

---

**LIST OF DETAILS**

- 100: Standard Erosion Control Notes for Construction
- 110: Construction Entrance – Gravel
- 115: LCPW Standard Silt Fence
- 120: Perimeter Control – Wattles
- 125: Wattle Installation Detail
- 130: Curb & Gutter Inlet Protection Detail
- 135: Catch Basin Barrier Protection
- 140: Catch Basin Barrier Protection II
- 145: Catch Basin Protection (Witch's Hat)
- 150: Matting Slope Installation
- 155: Surface Roughing Stair – Stepping/Grooving Slopes
- 160: Surface Roughing – CAT Track
- 165: Fill Pile Cover – Plastic Sheeting
- 170: Check Dam
- 175: Barrier Spacing Table
- 500: Pipe Clearance Standard
- 200: Sanitary Sewer Lateral Connection
- 210: LPS End of Line Flushing Station
- 211: Alternative End of Line Flushing Station
- 220: Standard Low Pressure Sewer Service
- 225: Standard Low Pressure Sewer Service – In Sidewalk
- 510: Standard Water Service – Off Sidewalk
- 511: Standard Water Service – 1-1/2" and 2"
- 515: Standard Water Service – On Sidewalk
- 535: Air Release/Air Vacuum Assembly
- 530: Dead End Blow-Off Assembly
- 540: Combination Low Point/Blow-off Assembly
- 520: Fire Hydrant
- 550: Valve Box & Operator Extension Assembly
- 320: LCPW On Site Storm – Drywell
- 315: LCPW Storm – Standard Service Lateral
- 400: Trench Cut
- 410: ADA-Mailbox & Obstruction Detail
- 420: Typical Sidewalk Cross-section
- 430: Roadway Patch Repair Detail
- 440: Residential Driveway
- 600: Grading Setbacks
- 610: Grading & Terracing
- 900: Concrete Washout Station

**LINCOLN CITY PUBLIC WORKS DEPARTMENT  
DESIGN STANDARDS**

801 SW Hwy 101 – PO Box 50, Lincoln City, OR 97367

Phone: (541) 996-2154 (City Hall General Information)

(541) 996-1013 (Public Works Administration and Inspection Requests)

---

**GENERAL PERMIT CONDITIONS**

The following Public Works Department standard permit conditions shall apply to and be attached or incorporated into multi-unit, commercial building, and civil infrastructure permit plans as part of the general notes.

These permit conditions are directed to the project owner &/or landowner (hereinafter “Owner”), their agent(s) (i.e. developer, contractor, engineer, architect, etc.) who are collectively responsible for compliance with these conditions.

1. All construction work under the jurisdiction of the Lincoln City Public Works Department (LC PWD) shall conform to the current versions of the Oregon Standard Specifications for Construction and Oregon Standard Drawings published jointly by the Oregon Department of Transportation (ODOT) and Oregon American Public Works Association (APWA), Americans with Disabilities Act (ADA) Standards, American Water Works Association (AWWA) Standards, Manual on Uniform Traffic Control Devices (MUTCD), and all applicable Lincoln City “Material and Construction Standards” (LC MCS) and the Municipal Code of Ordinances. The City Engineer shall determine any project-specific requirements that may deviate from the referenced standards if applicable and determine the order of precedence in the case of conflicting requirements.
2. A Public Works permit is required when any person, firm or corporation intends to install a facility in the City right-of-way, including but not be limited to streets, signs, poles, underground utilities, curb, gutters and sidewalks.
3. One (1) set of plans, in good condition, approved by the LC PWD shall be maintained on-site during all construction activity and shall be available at the site at all times. One (1) set of approved plans shall be used by the owner or their agent to record any deviations from the approved plans. Plans without the LC PWD approval stamp shall not be considered valid. The owner or their agent is responsible for ensuring copies of the approved plans are distributed to their project team members as necessary.
4. A preconstruction meeting with the LC PWD shall be scheduled by the owner or their agent at least 5-business days prior to the start of any construction activity. No construction activity shall begin until the preconstruction meeting has been held.
5. The owner or their agent shall call the Oregon Utility Notification Center (1-800-332-2344) at least 48-hours prior to the start of construction.
6. The owner or their agent shall provide a minimum of 48-hours notice to the LC PWD prior to the start of any project-related construction.
7. LC PWD inspections shall be scheduled to occur between 8:30 AM and 4:30 PM, Monday through Friday (no holidays).
8. The owner or their agent shall be responsible for the satisfactory installation of approved materials and subsequent performance of required public works construction work for a period of one (1) year after the date of final acceptance by the LC PWD.

**LINCOLN CITY PUBLIC WORKS DEPARTMENT  
DESIGN STANDARDS**

801 SW Hwy 101 – PO Box 50, Lincoln City, OR 97367

Phone: (541) 996-2154 (City Hall General Information)

(541) 996-1013 (Public Works Administration and Inspection Requests)

---

9. Within 30 days after construction is complete the owner or their agent shall submit a complete set of full-size, survey-verified record drawings. The record drawings shall be established in model space using the state plan coordinate system, Oregon North Zone 3601, with horizontal survey control of NAD 83 and vertical control of NAVD 88. The record drawings shall depict all changes from the approved plans made in the field by the contractor. Information shown on the record drawings shall include, but not be limited to, sanitary sewer connection, stormwater system, water services and vaults and any other service related structure or feature constructed under the site plan as well as actual locations, depths, sizes, arrangements, widths, slopes and other pertinent information for new utility or street construction within the public right-of-way or other locations noted by the LC PWD. LC PWD shall review the submitted record drawings (hard copy review set) for accuracy and completeness and shall require updates if warranted. Once the hard copy has been accepted, record drawings shall be provided via electronic AutoCAD file in disk format.
10. The owner or their agent shall be responsible for the repair of any damage to adjacent property or public right of way at no cost to the City.
11. Lots shall be only be served from public utilities along their lot frontage to the Right-of-Way or public utility easement. Should a parcel have no frontage or partial frontage on a public utility being requested, extension of the utility along the lots full frontage shall be required as a condition of establishing service.
12. An approved plan set for active right-of-way permits shall be kept on-site, at all times, until construction is complete and all final inspections have passed.
13. The owner or their agent shall be responsible for obtaining all additional permits required for the proposed work. (ODOT, DSL, ODEQ, OSP, etc.)

## CHAPTER 1- WATER

### General Requirements

1. The Material and Construction Standards in this Chapter shall govern local design and installation requirements for water mains, bell restraint harnesses, water valves, air release valves, valve boxes, fire hydrants, new services, tracer wire and testing requirements. If not indicated in this information, the current versions Oregon Standard Specifications for Construction and Oregon Standard Drawings shall apply unless otherwise noted by LC PWD.
2. Upon request of LC PWD, owner or their agent shall furnish certification(s) for all materials incorporated into the construction. Certification must include specific material information that shall indicate conformance to LC PWD requirements, including but not limited to, catalog cuts, test reports, etc.
3. Fire Department Connections (FDCs) shall be used on fire suppression systems located on private properties; no fire hydrants will be allowed on private properties. An approved Double Detector Check (DDC) backflow assembly shall be minimum protection on all fire suppression systems. The DDC shall be placed in a below ground vault. A detail of the vault shall be included in design drawings for review and approval by LC PWD. DDC vaults shall either be pre-cast structures OR structural design calculations shall be submitted with permit application for cast-in-place designs. DC & DDC assemblies shall be within 25 feet of the connection point to the public water system.
4. Services for 1-inch and smaller water meters shall automatically be installed by LC PWD at the property line within 30-days of payment of system development charges. The owner or their agent shall provide a minimum of 48-hours' notice to LC PWD prior to desired meter installation and service connection to City water system. The owner or their agent shall place a white stake at their preferred water meter location. Final water meter location shall be at the discretion of LC PWD.

*(Exclusion: New subdivisions and Planned Unit Developments. Services for created lots shall be installed as part of the required improvements. Services shall be placed in pairs at shared property lines whenever possible.)*

4. Billing for water (and sanitary sewer base) charges shall begin on the water meter installation date. The responsibility for payment of water (and sanitary sewer) charges rests with the property owner (City Ordinance 78-37).
5. If project service area is 150-feet or more above sea level, adequate water pressure is the responsibility of the property owner and may not be directly available from the City system.
6. Pipe connections to City water system, including fire hydrants and main extensions, shall be coordinated in advance with LC PWD. Owner or their agent shall provide a minimum of 5-business day's prior notice to LC PWD, and shall supply pertinent information on the desired system connection location(s), tapping sleeve(s) and/or fitting arrangement(s) and size(s), valving and other work proposed. LC PWD shall arrange for an on-site review with the owner or their agent of the proposed connection(s) within the 5-business day notice period. Final

**LINCOLN CITY PUBLIC WORKS DEPARTMENT  
DESIGN STANDARDS**

801 SW Hwy 101 – PO Box 50, Lincoln City, OR 97367

Phone: (541) 996-2154 (City Hall General Information)

(541) 996-1013 (Public Works Administration and Inspection Requests)

---

system connection requirements shall be as directed by LC PWD. Owner or their agent shall provide a minimum of 48-hours' notice to LC PWD prior to the actual connection work per location. LC PWD shall be present prior to starting construction to observe and inspect the connection work.

7. The owner or their agent shall call for water pipeline inspection at least 48-hours prior to the start of pipe laying. LC PWD must be able to observe new water system materials & general installation adequacy. LC PWD inspection extent and duration shall be determined at the time of construction. Pipeline inspection must pass before trench or pit is backfilled. Water pipelines not inspected/or in noncompliance shall be required to be uncovered and/or corrected at the owner's expense.
8. Backfill of water pipeline trenches and pits shall conform to the Material and Construction Standards within this chapter.
9. New water systems shall be hydrostatically pressure tested at no less than 150-psi for two hours following backfill placement prior to final street paving or final surface restoration if outside street areas. Conform to testing requirements in the current version of the Oregon Standard Specifications for Construction unless otherwise noted by LC PWD. LC PWD shall determine minimum test pressure required and shall witness the pressure testing; provide a minimum of 48-hours notice to LC PWD prior to start of any and all tests.
10. Bacteriological treatments and testing of new water systems shall be the responsibility of the owner or their agent. Acceptable test results from a certified laboratory approved by the Oregon Department of Health Services Water Program shall be provided to the LC PWD prior to final acceptance of the new water system for public use.
11. Advance coordination with LC PWD is required for new water system flushing. Owner or their agent shall provide a minimum of 48-hours notice prior to start of new water system flushing, and Owner or their agent shall include a proposed plan for disposal/neutralization of chlorinated water.
12. Fire hydrants shall be "bagged" (i.e. out of service) until LC PWD has accepted the new water system for public use.
13. Existing City water system valves or fire hydrants shall not be operated, tampered with or in any way changed by anyone except the LC PWD water personnel or fire department staff. Use of and payment for water from the existing City system shall be arranged in advance through the LC PWD.
14. Final water system inspection required, provide a minimum of 48-hours prior notice to LC PWD.
15. All abandoned water mains and services shall be removed back to the closest valve. Exceptions to this shall be completed only after written approval from Lincoln City Public Works. Additionally requirements may include the installation of mechanically restrained caps on cut pipe ends, concrete plug installation, or utilization of a CLSM slurry (*submittal required*).

**LINCOLN CITY PUBLIC WORKS DEPARTMENT  
DESIGN STANDARDS**

801 SW Hwy 101 – PO Box 50, Lincoln City, OR 97367

Phone: (541) 996-2154 (City Hall General Information)

(541) 996-1013 (Public Works Administration and Inspection Requests)

---

**Inspection/Testing Notification**

- Advance coordination is required for ALL pipe connections to City water system - provide a minimum of 5-business days prior notice to LC PWD
  - Pipeline inspection is required for all water system construction including visual, compaction, pressure testing, chlorination, and flushing - provide a minimum of 48-hours prior notice to LC PWD
  - LC PWD shall make periodic general inspections of work in progress, notice of problems shall be provided to owner or their agent as necessary
16. The owner or their agent shall provide “record drawings” to LC PWD of the new water facilities prior to final project acceptance.
17. The owner or owner’s agent shall be responsible for testing & verifying the sufficiency of existing pressures & flows for domestic & fire requirements of proposed developments. Lincoln City Water Distribution crews shall be notified 48-hours prior to scheduled pressure and/or flow testing.

**Material and Construction Standards**

**Water Mains**

1. All 4-inch to 12-inch diameter water main pipe installed shall be DR 18, C-900 PVC pipe unless otherwise directed by LC PWD.
2. All 16-inch and larger diameter water main pipe installed shall be DR 25, C-905 PVC pipe unless otherwise directed by LC PWD.
3. All water main pipe fittings shall be domestic brand ductile iron.
4. Pipe bedding shall be 6-inches compacted  $\frac{3}{4}$ -inch minus crushed rock regardless of soil type or condition of soils. Compaction shall be by vibratory plate (whacker) or jumping jack to 95% compaction.
5. Backfill in trench shall be  $\frac{3}{4}$ -inch minus crushed rock compacted in 12-inch maximum lifts within pipe zone to 95% compaction by vibratory plate, jumping jack, or hoe-pac.
6. For areas within public street pavement, backfill shall be controlled low slump material (CLSM) as requested by LCPW.
7. All “Hot Tapping” sleeves shall be 100% Stainless Steel.

**Bell Restraint Harness**

8. Restraints for bell and spigot joints shall be series 1600 Bell Restraint Harnesses. Restraint harnesses shall include a serrated grip ring for installation on the spigot end and a non-serrated ring for installation behind the bell. Ring material shall be ductile iron conforming to ASTM A536. Harness rods, ring bolts, and nuts shall be type 304 stainless steel. Restraint harness assemblies shall be designed with a safety factor of at least 3.0 and shall have a rated working pressure equal to the pressure rating of the attached pipe.

**LINCOLN CITY PUBLIC WORKS DEPARTMENT  
DESIGN STANDARDS**

801 SW Hwy 101 – PO Box 50, Lincoln City, OR 97367

Phone: (541) 996-2154 (City Hall General Information)

(541) 996-1013 (Public Works Administration and Inspection Requests)

---

**Water Valves**

9. All gate valves shall be domestic brand and shall conform to the latest revision of the AWWA resilient seated gate valve standard C-509, be UL listed, and approved for working pressures of 200-psi. No imports shall be accepted.
10. All butterfly valves shall be domestic brand and shall conform to the latest revision of the AWWA resilient seated butterfly valve standard C-504, be UL listed, and approved for working pressures of 200-psi. No imports shall be accepted.

**Air Release Valves**

11. All air release valves shall be D-40 ¾” 1” Combination Air Valve “Barak” or D-40 2” Combination Air Valve “Barak” by A.R.I. USA, Inc.

**Valve Boxes**

12. Valve boxes shall be Vancouver 910 with VC-212 and 3034 pipe.

**Fire Hydrants**

13. All fire hydrants shall be Kennedy K81D unless otherwise directed by LC PWD.
14. Fire hydrants shall be painted reflective yellow.
15. In areas of high traffic exposure, backing, and turning vehicles, 4-inch diameter steel bollards shall be installed for protection. Bollards shall be no less than 36-inches in distance from the hydrant barrel and shall be painted reflective yellow. Reflective tape strips may also be used as supplementary visibility markings. Final arrangement of bollard protection shall be based on the approval of the North Lincoln Fire & Rescue District #1 Division Chief/Fire Marshall.

**Services 2-inches and smaller**

16. Saddles shall be Romac 101NS with Iron Pipe Size (IPS) threads and 316 stainless steel single strap for 1-inch taps and Romac 202NS with IPS threads and 316 stainless steel double strap for 2-inch taps. 2-inch taps may alternatively use a tee or tapping sleeve. Any tap over 2-inches requires a 316 stainless steel tapping sleeve.
17. Corporation stops shall be Ford F500 or their domestic equivalent to be approved by LC PWD prior to installation. All service fittings shall be **brass**, male x male, iron pipe size, and iron pipe thread.
18. All water service pipe for 5/8-inch to 1-inch meters shall be 1-inch diameter IPS, blue, polyethylene pipe with a 200-psi pressure rating. Use **stainless** inserts on all compression fittings.
19. All water service pipe for 1½-inch to 2-inch meters shall be 2-inch diameter IPS, blue, polyethylene pipe with a 200-psi pressure rating and 2-inch meter setters, 1-inch **side** bypasses, and 2-inch non-rising stem (NRS) resilient seat gate valve(s) unless otherwise directed by the LC PWD.

**LINCOLN CITY PUBLIC WORKS DEPARTMENT  
DESIGN STANDARDS**

801 SW Hwy 101 – PO Box 50, Lincoln City, OR 97367

Phone: (541) 996-2154 (City Hall General Information)

(541) 996-1013 (Public Works Administration and Inspection Requests)

---

20. For services larger than 2" vault, backflow, and meter details shall be submitted with civil plans and constructed according to the city permitted plans. Domestic and/or irrigation vaults shall either be pre-cast structures OR structural design calculations shall be submitted with permit application for cast-in-place designs.
21. Curb Stops shall be brass full port ball valve, 1-inch IPS, straight, Ford B63-444W-G, or 1-inch IPS, angle, Ford KV43-444W-G, or the domestic equivalent to be approved by LC PWD prior to installation.
22. Customer valves shall be globe meter valve, ¾-inch IPS, straight, Ford SG13-332 or ¾-inch IPS, 90-degree angle, Ford GA13-332, or the domestic equivalent to be approved by LC PWD prior to installation.
23. Meters - All domestic water meters shall be Sensus iPearl for 1-inch and smaller meters. Meters larger than 1-inch shall be Sensus Omni-C2. All meters shall register in cubic feet.
24. Meter Boxes - ARMORCAST A6000485 OR FIBERLYTE FL12 shall be used for ¾-inch and 1-inch meters. ARMORCAST AA6001640PCX12 (17"x30") OR FIBERLYTE FL36 shall be used for 1½-inch and 2-inch meters. (certain applications may require meter boxes with higher traffic ratings).
25. Meter Box Lids- All meter box lids shall be provided with the AMR/AMI knockout and be manufacturer stamped "WATER". ARMORCAST A6000484 shall be provided for ¾-inch and 1-inch meters. ARMORCAST A6001640TAPCX18 shall be provided for 1½-inch and 2-inch meters. All lids and/or alternatives shall be 20k rating unless otherwise approved in writing by LCPWD.
26. Water service lines shall not be placed within 5-feet of sanitary sewer laterals or within 3-feet of any power, telephone, cable, or gas service lines without prior written approval from LC PWD.
27. Water service lines shall be stamped with "W" at actual location in all new curbs.
28. New water services shall be placed at shared property lines, adjacent to the neighboring meter, whenever possible.

**Tracer Wire**

29. Tracing wire for trench installations shall be 12-gauge single strand, with blue insulation, and it shall be installed along the crown of all mains, services, and stubs.
30. Install tracer wire per the most recent Oregon Standard Specifications for Construction,
31. Tracer wire for trenchless installations shall be Copperhead 12 CCS Directional Drill Wire 1150# Break Load (SoloShot), or approved equal, with blue jacket color, and it shall be installed along the crown of all mains, services and stubs that are installed using trenchless technology.
32. Daylight tracer wire in all valve and meter boxes a maximum of 3-inches from surface grade.
33. For City projects involving irrigation systems, tracer wire shall be used to mark all lines from valve box to end of lines.

**LINCOLN CITY PUBLIC WORKS DEPARTMENT  
DESIGN STANDARDS**

801 SW Hwy 101 – PO Box 50, Lincoln City, OR 97367

Phone: (541) 996-2154 (City Hall General Information)

(541) 996-1013 (Public Works Administration and Inspection Requests)

---

**Testing Requirements**

34. All testing shall be done in the presence of a designated LC PWD representative or the test shall be considered invalid.
35. The water main shall be thoroughly flushed clean of all sediments, drill tailings, etc. prior to testing and connection to the City's existing potable water system. Blow-off/ Evacuation tap shall have a minimum flow velocity of 2.5-fps per the most current edition of the Oregon Standard Specifications for Construction, Section 1140.50(a). Large diameter lines (8" and larger) shall have pipe belly's pigged to remove remaining sediment.
36. The water main shall be filled through a bypass connection with check valve, water truck, or other means that does not directly connect to the City's existing potable water system with a flow rate of 1-fps per the most current edition of the Oregon Standard Specifications for Construction, Section 1140.50. The contractor shall ensure that there is no residual air trapped within the filled water main prior to pressure testing.
37. Once filled, the water main shall be pressurized to no less than 150-psi (NO EXEPTIONS) via pump with a **certified pressure gauge**. The test period duration shall be two (2) hours. Provide additional pumping during the test period to maintain pressure in the pipe within 5-psi of that required per the most current edition of the Oregon Standard Specifications for Construction, Sections 1140.51(a)(3-11). There shall be no appreciable or abrupt pressure loss during the test period.
38. Pressure test section lengths shall not exceed 1,500-feet, unless longer test sections are approved in writing by the City Engineer.
39. Pressure testing for main extensions shall comply with the most current edition of the Oregon Standard Specifications for Construction, Section 1140.51(b-d).
40. When the water main pressure test has been passed it must be thoroughly disinfected. Chlorination of the new water main shall be by Sodium Hypochlorite per the most current edition of the Oregon Standard Specifications for Construction, Section 1140.52(b)(3). Initial chlorine content of the water shall be no greater than 100-ppm with a 24-hour residual content of not less than 50-ppm. Application shall be through a corporation stop at the beginning of the pipeline. Elevation of the main should also be taken into consideration when applying chlorine into the main since the chlorine is heavier than water and shall settle in the low spots of the pipe.
41. Upon satisfactory disinfection, the chlorinated water in the main shall be flushed through a dechlorination device with an application rate of neutralizing agent sufficient to achieve a chlorine residual of zero when tested. Water shall be discharged to an area or structure as approved in writing by the City Engineer.
42. After the water main has been dechlorinated and refilled, a water sample shall be taken in a laboratory supplied container for every 500-feet of water main. This sample shall be sealed and initialed by a representative of LC PWD witnessing the sampling. These samples shall be taken to a certified lab by the owner/developer/contractor per the current AWWA standards and

**LINCOLN CITY PUBLIC WORKS DEPARTMENT  
DESIGN STANDARDS**

801 SW Hwy 101 – PO Box 50, Lincoln City, OR 97367

Phone: (541) 996-2154 (City Hall General Information)

(541) 996-1013 (Public Works Administration and Inspection Requests)

---

specifications. Should the City seal on the test containers arrive at the laboratory broken or altered in any fashion, that sample shall be considered unacceptable for testing.

43. A second set of water samples shall be taken 24-hours after the first set of samples at the same sample points with the same criteria as the first set of samples.
44. The testing laboratory shall provide a written report of their results to both LC PWD and the project owner/developer/contractor.
45. There shall be no connection of non-disinfected water main to any existing City water main until all testing has been completed and accepted.

## CHAPTER 2- SANITARY SEWER

### **General Requirements**

1. The Material and Construction Standards in this chapter shall govern local design and installation requirements for sanitary sewer mains, lateral taps and saddles, manholes, tracer wire, private pumping systems and testing requirements. If not indicated in this information, the current versions of the Oregon Standard Specifications for Construction and Oregon Standard Drawings shall apply unless otherwise noted by LC PWD.
2. Engineered sanitary sewer mainline extensions shall be submitted to the Oregon Department of Environmental Quality (ODEQ) for review & approval. Documentation of submittal and final approval shall be submitted prior to applicant request for final acceptance.
3. Upon request of LC PWD, owner or their agent shall furnish certification(s) for all materials incorporated into the construction. Certification must include specific material information that shall indicate conformance to LC PWD requirements, including but not limited to, catalog cuts, test reports, etc.
3. The owner or their agent shall call LC PWD for pipeline inspection 48-hours prior to start of sanitary sewer pipe laying within public right-of-way or other locations noted by LC PWD. LC PWD must be able to observe new sanitary sewer system materials & general installation adequacy. LC PWD inspection extent and duration shall be determined at the time of construction. Pipeline inspection must pass before trench or pit is backfilled. Pipelines not inspected/or found to be in noncompliance shall be required to be uncovered and/or corrected at the owner's expense.
4. Pipe connections to City sanitary sewer system, including mainline extensions or laterals, shall be coordinated in advance with LC PWD. Owner or their agent shall provide a minimum of 5-business days prior notice to LC PWD, and shall supply pertinent information on the desired system connection(s) location(s), tapping sleeve(s)/saddle arrangement(s) and size(s), existing manhole modification(s), new manhole installation(s) or other work proposed. LC PWD shall arrange for on-site review with the owner or their agent of the proposed connection(s) within the 5-business day notice period. Final system connection requirements shall be as directed by LC PWD. Owner or their agent shall provide a minimum of 48-hours notice to LC PWD prior to the actual connection work per location. LC PWD shall be present prior to starting construction to observe and inspect the connection work. Connections to City sanitary sewer system not inspected/or found to be in noncompliance shall be required to be uncovered and/or corrected at the owner's expense.
5. The owner or their agent shall provide “record drawings” to LC PWD of the new sanitary sewer facilities prior to final project acceptance.
5. All existing septic tanks shall be decommissioned in accordance with Oregon Department of Environmental Quality (ODEQ) requirements. The owner or their agent shall be responsible for providing to LC PWD a written plan for decommissioning of existing septic tanks prior to start of construction. Generally this shall require that the septic tank be either (1) pumped and filled with sand, or (2) removed and disposed of at a licensed site by a contractor licensed by ODEQ

**LINCOLN CITY PUBLIC WORKS DEPARTMENT  
DESIGN STANDARDS**

801 SW Hwy 101 – PO Box 50, Lincoln City, OR 97367

Phone: (541) 996-2154 (City Hall General Information)

(541) 996-1013 (Public Works Administration and Inspection Requests)

---

for such removal. Sealing/capping existing sewer pipe from building to septic tank shall be done in conjunction with new sanitary sewer lateral connection. Owner or their agent shall provide to LC PWD documentation within 5-business days after tank decommissioning (i.e. receipt from the tank disposal site &/or certificate of work by licensed contractor).

6. Backfill of sanitary sewer pipeline trenches and pits shall conform to the Material and Construction Standards within this chapter.
7. New sanitary sewer systems shall be tested following backfill placement and prior to final street paving or final surface restoration if outside street areas. Conform to testing requirements in the current version of the Oregon Standard Specifications for Construction unless otherwise noted by LC PWD. Testing shall include, but may not be limited to, low-pressure air test, mandrel test, manhole leak test and inspection via remote camera per the most current edition of the Oregon Standard Specifications for Construction, Section 00445.74. This inspection recording shall be submitted on CD in digital format to LC PWD. LC PWD shall determine the tests required and shall witness the testing; provide a minimum of 48-hours notice to LC PWD prior to the start of any and all tests.
8. Ends of sanitary sewer laterals shall be located by a 2"x4" post, with the top painted green and depth to pipe marked. A continuous length of 12-gauge, single strand tracer wire with green insulation shall stretch from the underground sanitary sewer lateral to daylight at the 2"x4" locate post.
9. Final sanitary sewer system inspection required, provide a minimum of 48-hours prior notice to LC PWD.

10. Inspection Summary

- Advance coordination required for pipe connections to City sanitary sewer system, provide a minimum of 5-business days prior notice to LC PWD
- Provide a minimum of 48-hours notice to LC PWD prior to pipe connections to City sanitary sewer system, pipeline inspection(s), testing, and final sewer system inspection(s).
- LC PWD shall make periodic general inspections of work in progress, notice of problems shall be provided to owner or their agent as necessary
- Follow up problem correction(s) by the owner or their agent upon notice by LC PWD; failure to correct problems in timely manner may result in a violation.
- The decommissioning of septic tanks shall be documented to LC PWD.

## **Material and Construction Standards**

### **Sanitary Sewer Mains**

1. All sanitary sewer force main pipe installed shall be Class 150 C-900 PVC for 4-inch diameter and larger pressure lines unless otherwise directed by LC PWD.

**LINCOLN CITY PUBLIC WORKS DEPARTMENT  
DESIGN STANDARDS**

801 SW Hwy 101 – PO Box 50, Lincoln City, OR 97367

Phone: (541) 996-2154 (City Hall General Information)

(541) 996-1013 (Public Works Administration and Inspection Requests)

---

2. All sanitary sewer gravity pipe shall be a minimum of 8-inches in diameter and shall be Class 150 C-900 PVC or 3034 SDR 35 unless otherwise directed by LC PWD.
3. Pipe bedding shall be 6-inches compacted  $\frac{3}{4}$ -inch minus crushed rock regardless of soil type or condition of soils. Compaction shall be by vibratory plate (whacker) or jumping jack to 95% compaction.
4. Backfill in trench shall be  $\frac{3}{4}$ -inch minus crushed rock compacted in 12-inch maximum lifts within pipe zone to 95% compaction by vibratory plate, jumping jack, or hoe-pac.
5. Compaction testing shall be completed/contracted by the applicant & submitted to Lincoln City Public works OR compaction methods shall be witnessed & documented throughout completion by a designated, Lincoln City public works employee.
6. For areas within public street pavement, the top 12-inches of backfill shall be CLSM.

**Sanitary Sewer Lateral Taps and Saddles**

7. Sanitary sewer lateral taps shall be drilled into main lines. No lateral connections are allowed directly into manholes.
8. Sanitary sewer saddles shall be stainless steel, Romac Style “CB” Sewer Saddles.
9. Factory tees shall be used for lateral placement along sanitary sewer mainline extensions unless otherwise approved in writing by the city engineer.
10. Sanitary sewer lateral lines shall not be placed within 5-feet of any water service line or within 3-feet of any power, telephone, cable, or gas service lines without prior approval from LC PWD.

**Sanitary Sewer Manholes**

11. Sanitary sewer manholes shall be pre-cast 48-inch diameter minimum with standard frame(s) and lid(s) unless otherwise directed by LC PWD. Bottoms shall be pre-cast with rubber boot adapters for pipe installation. All sanitary sewer manholes shall be constructed per Oregon Standard Drawing RD338.
12. Ladder rungs shall be required on all sanitary sewer manholes.
13. Sanitary sewer manhole lids shall have two holes.
14. Standard manhole lids and rims shall be cast iron and traffic rated.
15. Manholes shall be placed at all mainline junctures, direction changes, and ends of a line.

**Tracer Wire**

16. Tracer wire shall be single strand 12-gauge with green insulation.
17. Tracer wire shall be installed along crowns of all sanitary sewer mains, laterals, and stubs.
18. Install tracer wire per the most current edition of the Oregon Standard Specifications for Construction, Section 00445.48.

**LINCOLN CITY PUBLIC WORKS DEPARTMENT  
DESIGN STANDARDS**

801 SW Hwy 101 – PO Box 50, Lincoln City, OR 97367

Phone: (541) 996-2154 (City Hall General Information)

(541) 996-1013 (Public Works Administration and Inspection Requests)

---

19. Daylight tracer wire in all sanitary sewer manholes to manhole lids, clean-outs to clean-out lids, and at lateral markers a minimum of one foot above surface grade.

**Low Pressure Sewer Mains**

20. The owner or their agent must submit to LC PWD (Lincoln City Public Works Department) an application requesting approval of a low pressure sanitary pump system to serve their property if their property is not already in an area that is designated for Low Pressure Sanitary Pump System. The City Engineer shall review the application and determine whether a low pressure sanitary pump system is appropriate for this property or if the property should be served by a gravity sewer system. **SEE CHAPTER 4**

**Testing Requirements**

21. All testing shall be done in the presence of a designated LC PWD representative or the test shall be considered invalid.
22. The sanitary sewer main and structures shall be clean of all sediment prior to testing.
23. The sanitary sewer main shall be mandrel tested per the most current edition of the Oregon Standard Specifications for Construction, Section 00445.73.
24. The sanitary sewer main shall be pressure tested per the most current edition of the Oregon Standard Specifications for Construction, Section 00445.72(c).
25. Once the sanitary sewer main has been successfully mandrelled and pressure tested, the line shall be inspected via remote camera per the most current edition of the Oregon Standard Specifications for Construction, Section 00445.74. This inspection recording shall be submitted on CD in digital format to the LC PWD.
26. Manholes shall be vacuum tested per ODEQ requirements after all paving has been completed. Tests done prior to paving shall not be considered valid per the most current edition of the Oregon Standard Specifications for Construction, Section 00470.71. Vacuum testing shall conform to the most current edition of the Oregon Standard Specifications for Construction, Section 00470.71(b).

**LINCOLN CITY PUBLIC WORKS DEPARTMENT  
DESIGN STANDARDS**

801 SW Hwy 101 – PO Box 50, Lincoln City, OR 97367

Phone: (541) 996-2154 (City Hall General Information)

(541) 996-1013 (Public Works Administration and Inspection Requests)

---

**CHAPTER 3- STORMWATER SYSTEM**

**General Permit Requirements**

1. The Material and Construction Standards in this chapter shall govern local design and installation requirements for stormwater drainage construction. If not indicated in this information, the current versions of the Oregon Standard Specifications for Construction and Oregon Standard Drawings shall apply unless otherwise noted by LC PWD.
2. Upon request of LC PWD, owner or their agent shall furnish certification(s) for all materials incorporated into the construction. Certification must include specific material information that shall indicate conformance to LC PWD requirements, including but not limited to, catalog cuts, test reports, etc.
3. The owner or their agent shall call LC PWD for inspection of all stormwater drain pipe and structures within the public right-of-way and all detention structures and outflow control devices installed or modified as a result of their project. Provide a minimum of 48-hours notice to LC PWD prior to placement of backfill. LC PWD must be able to observe new stormwater system materials and general installation adequacy. LC PWD inspection extent and duration shall be determined at the time of construction. Pipeline inspection must pass before trench or pit is backfilled. Stormwater facilities not inspected/or found to be in noncompliance shall be uncovered and/or corrected at the owner's expense.
4. Pipe connections to City stormwater system, including mainline extensions or laterals, shall be coordinated in advance with LC PWD. The owner or their agent shall provide a minimum of 5-business days prior notice to LC PWD, and shall supply pertinent information on the desired system connection(s) location(s), tapping sleeve(s)/saddle arrangement(s) and size(s), existing manhole modification(s), new manhole installation(s) or other work proposed. LC PWD shall arrange for on-site review with the owner or their agent of the proposed connection(s) within the 5-business day notice period. Final system connection requirements shall be as directed by LC PWD. The owner or their agent shall provide a minimum of 48-hours notice to LC PWD prior to the actual connection work per location. LC PWD shall be present prior to starting construction to observe and inspect the connection work. Connections to City stormwater facilities not inspected/or found to be in noncompliance shall be uncovered and/or corrected at the owner's expense.
5. The owner or their agent shall provide "record drawings" to LC PWD of the new stormwater drainage system prior to final project acceptance.
6. Backfill of stormwater drainage pipeline trenches and pits shall conform to the Material and Construction Standards within this chapter.
7. New stormwater systems shall be tested following backfill placement and prior to final street paving or final surface restoration if outside street areas. Conform to testing requirements in the current version of the Oregon Standard Specifications for Construction unless otherwise noted by LC PWD. Testing shall include, but not be limited to, low-pressure air test, mandrel test, manhole leak test and inspection via remote camera per the most current edition of the Oregon Standard Specifications for Construction, Section 00445.74. This inspection recording shall be

**LINCOLN CITY PUBLIC WORKS DEPARTMENT  
DESIGN STANDARDS**

801 SW Hwy 101 – PO Box 50, Lincoln City, OR 97367

Phone: (541) 996-2154 (City Hall General Information)

(541) 996-1013 (Public Works Administration and Inspection Requests)

---

submitted on CD in digital format to LC PWD. LC PWD shall determine the tests required and shall witness the testing; provide a minimum of 48-hours notice to LC PWD prior to the start of any and all tests.

8. Final stormwater drainage system inspection is required, provide a minimum of 48-hours prior notice to LC PWD.

9. Inspection Summary

- Advance coordination required for pipe connections to City stormwater drainage system, provide a minimum of 5-business days prior notice to LC PWD
- Provide a minimum of 48-hours notice to LC PWD prior to any pipe connection(s), pipeline installation(s), testing, and inspection(s).
- LC PWD shall make periodic general inspections of work in progress, notice of problems shall be provided to owner or their agent as necessary
- Follow up problem correction(s) by the owner or their agent upon notice by LC PWD; failure to correct problems in timely manner may result in a violation

**Erosion Control**

- 1) An erosion control plan shall be included with permit applications in accordance with LCMC 12.08
- 2) With the exception of single-family dwelling or duplex dwelling developments, erosion control plans shall be prepared by a Registered Professional Engineer, Landscape Architect, Engineering Geologist, or Certified Professional in Erosion & Sediment Control.
- 3) If a construction activity disturbs more than one (1) acre, the applicant shall be responsible for acquiring and adhering to Oregon DEQ’s 1200-C Stormwater permit.

**Design Storm**

The stormwater system shall be designed using the 2-year, 24-hour event; 10-year, 24-hour event; and the 25-year, 24-hour event. Isopluvial precipitation maps for Lincoln City may be found on-line at <https://wrcc.dri.edu/>. The values shown in the table below may also be used for convenience.

	<b>2-year, 24 hr</b>	<b>10-year, 24 hr</b>	<b>25-year, 24 hr</b>	<b>50-year, 24 hr</b>	<b>100-yr, 24 hr</b>
<b>Rainfall (in)</b>	4.2	5.7	6.5	7.0	7.5

Source- Western US Precipitation Frequency Maps, NOAA Atlas 2 published in 1973

Alternate values may be used if the source is consistent with the NRCS Type 1A 24-hour storm distribution methodology.

**Design Methodology**

Stormwater calculations for conveyance, infiltration, detention, water quality, and proposed drainage facilities shall be submitted with permit applications. Stormwater calculations beyond the simplified methods put forward within Lincoln City’s on-site Stormwater BMPs shall be submitted as part of a

**LINCOLN CITY PUBLIC WORKS DEPARTMENT  
DESIGN STANDARDS**

801 SW Hwy 101 – PO Box 50, Lincoln City, OR 97367

Phone: (541) 996-2154 (City Hall General Information)

(541) 996-1013 (Public Works Administration and Inspection Requests)

---

stormwater report. Submitted reports shall be stamped by a licensed professional engineer and demonstrate compliance with Lincoln City’s Stormwater BMPs and standards.

The Santa Barbara Urban Hydrograph method shall be used to determine the runoff hydrograph(s) of the project site. When determining impacts of the post-development runoff on the project site, the design engineer shall also include in their report a quantitative study of the impacts upstream of the project site and downstream for a distance of 400-yards or the nearest ocean/lake outfall, whichever is closer.

### **Detention**

Detention is required for all commercial, planned unit developments and subdivision projects. Detention shall provide run-off controls such that post-development flow rates leaving the site are no greater than pre-development flow rates unless authorized by the City Engineer in writing. The Design Storm shall be used to measure the pre- and post-development flow rates for purposes of calculation.

A level pool summary table shall be provided in the drainage report/calculations submitted with the design.

### **Outflow Control**

Outflow control structures shall be located so that they are fully accessible by vehicle for maintenance purposes with the access way elevation a minimum of 12-inches above the designed high water elevation.

Where the outflow control structure is not within or immediately adjacent to a roadway, the designer shall provide a rock surface vehicular access road capable of supporting vehicles up to 90,000-lbs.

### **Water Quality**

Water quality facilities are required for all pollutant generating, impervious surface on multi-family, commercial, planned unit developments, and subdivision projects. Facilities shall follow the Oregon Department of Environmental Quality requirements and regulations and shall be designed in accordance with the City’s Stormwater Best Management Practices for Site Development design guidelines. Water Quality shall be designed according to 50% of the 2-year, 24-hour event or using the simplified sizing percentages provided within Lincoln City’s stormwater BMPs. Access for maintenance of each water quality facility shall be provided. A water quality facility shall be installed prior to any discharge from the project site/roadway to any existing water body within the City. The types of acceptable water quality facilities are as follows:

- **Biofiltration Swales**
- **Drywells**
- **Infiltration Trenches**
- **Rain Gardens**
- **Planters**
- **Porous Pavements**
- **Stormwater Wetlands**
- **Detention Ponds**

**LINCOLN CITY PUBLIC WORKS DEPARTMENT  
DESIGN STANDARDS**

801 SW Hwy 101 – PO Box 50, Lincoln City, OR 97367

Phone: (541) 996-2154 (City Hall General Information)

(541) 996-1013 (Public Works Administration and Inspection Requests)

---

**Proprietary water quality facilities within the right-of-way or intended for public dedication and maintenance shall not be allowed without explicit written approval from LCPW prior to construction.**

The use and applicability of the above, standard water quality facilities, shall be evaluate for each site prior to any proposal. A detailed report of this evaluation and the reason for proposal of a proprietary water quality facility shall be prepared and stamped by a registered professional engineer and submitted to LCPW for review with the proposed stormwater report.

For specific applicability, site constraints and design guidance for these water quality facilities refer to LC PWD’s Stormwater Best Management Practices for Site Development design guidelines. Water quality facility designs must be approved via LC PWD prior to construction. Inspection by LC PWD to determine whether or not water quality facilities have been constructed in accordance with their approved designs must be passed prior to final acceptance by LC PWD.

### **Material and Construction Standards**

#### **Stormwater Drain Pipeline**

1. All stormwater drain pipe installed shall be:
  - ◆ N-12 HDPE or
  - ◆ PVC (ASTM D 3034) SDR 35 unless otherwise directed by LC PWD.
2. Pipe size shall be 12-inch diameter minimum within City right-of-way. Private drainage systems and culverts shall be sized for the 24-hour duration, 25-year storm event.
3. Pipe bedding shall be 6-inches compacted ¾-inch minus crushed rock regardless of soil type or condition of soils. Compaction shall be by vibratory plate (whacker) or jumping jack to 95% compaction.
4. Backfill in trench shall be ¾-inch minus crushed rock compacted in 12-inch maximum lifts within pipe zone to 95% compaction by vibratory plate, jumping jack, or hoe-pac. Between pipe zone and existing grade
5. Areas outside of public street pavement backfill may be rock to existing grade. Excavated native soil may be used outside of any public or private street or driveway. All material must be approved for use by LC PWD prior to placement.
6. For areas within public street pavement, the top 12-inches of backfill shall be CLSM. See standard trench detail.
7. Daylighted ends of pipe shall be bevel cut to match slope and protrude no more than 3-inches from grade.

#### **Catch Basins and Inlets**

8. Catch basins and inlets shall be pre-cast or cast in place concrete with 18-inch minimum sump.
9. Catch basins, inlets and area drains in streets or parking areas without sidewalk or curb shall be constructed in accordance with Oregon Standard Drawing RD374.

**LINCOLN CITY PUBLIC WORKS DEPARTMENT  
DESIGN STANDARDS**

801 SW Hwy 101 – PO Box 50, Lincoln City, OR 97367

Phone: (541) 996-2154 (City Hall General Information)

(541) 996-1013 (Public Works Administration and Inspection Requests)

---

10. Catch basins in streets or parking areas with sidewalk, curb, and gutter shall be constructed in accordance with Oregon Standard Drawing RD364, RD366, RD371, RD372, RD373 or RD378.
11. Ditch inlets shall be constructed in accordance with Oregon Standard Drawing RD370.
12. Manhole catch basins shall be constructed in accordance with Oregon Standard Drawing RD340 with a manhole grate installed in accordance with Oregon Standard Drawing RD356.
13. Manholes located in traffic areas shall have a suburban manhole cover and frame for stormwater per Oregon Standard Drawing RD356. Manhole lids shall be marked with the word “STORM” for stormwater drainage system.
14. Manhole lids and rims shall be cast iron and traffic rated.
15. Pipe connection between structures shall be direct from structure to structure. Blind tees and wyes shall not be allowed without written approval from LC PWD.
16. All runoff from new street construction, developments, and parking areas shall pass through a LC PWD approved water quality control structure prior to discharge to the down stream receiving waters. Details and sizing calculations for the proposed water quality control structure(s) shall be included with submittal and/or as part of the engineer design drawings.

**Outfall(s)/Discharge(s)**

17. Stormwater discharges shall be piped to the toe of substantial slopes (>20%) whenever possible.
18. Stormwater piping installed adjacent to coastal bluffs shall be underground via directional bore to the toe of the slope.
19. Outfalls shall be designed to provide energy dissipation and dispersal/spreading of the concentrated flows to eliminate the potential erosion of the existing soils, vegetation, existing channel bottom, etc. at the discharge point.
20. The design engineer shall include all detail(s) necessary for construction of the outfall(s)/discharge(s) within the construction drawings for review by LC PWD.

**Tracer Wire**

21. Tracer wire shall be single strand 12-gauge with green insulation.
22. Tracer wire shall be installed along crowns of all stormwater sewer pipes and stubs.
23. Install tracer wire per the most current edition of the Oregon Standard Specifications for Construction, Section 00445.48.
24. Daylight tracer wire in all stormwater sewer manholes to manhole lids, catch basins to catch basin lids clean-outs to clean-out lids, and at all stormwater sewer stub outs to a minimum of one foot above surface grade.

**LINCOLN CITY PUBLIC WORKS DEPARTMENT  
DESIGN STANDARDS**

801 SW Hwy 101 – PO Box 50, Lincoln City, OR 97367

Phone: (541) 996-2154 (City Hall General Information)

(541) 996-1013 (Public Works Administration and Inspection Requests)

---

**Testing Requirements**

25. All testing shall be done in the presence of a designated LC PWD representative or the test shall be considered invalid.
26. The stormwater drain main and structures shall be clean of all sediment, construction debris, etc. prior to testing.
27. The stormwater drain main shall be mandrel tested per the most current edition of the Oregon Standard Specifications for Construction, Section 00445.73.
28. Once the stormwater drain main has been successfully mandrelled, the line shall be inspected via remote camera per the most current edition of the Oregon Standard Specifications for Construction, Section 00445.74. This inspection recording shall be submitted on CD in digital format to LC PWD.

## **CHAPTER 4 - LOW PRESSURE SANITARY PUMP SYSTEMS**

### **General Requirements**

1. The owner or their agent must submit to LC PWD (Lincoln City Public Works Department) an application requesting approval of a low pressure sanitary pump system to serve their property if their property is not already in an area that is designated for Low Pressure Sanitary Pump System. The City Engineer shall review the application and determine whether a low pressure sanitary pump system is appropriate for this property or if the property should be served by a gravity sewer system.

### **Public System (Mainline)**

2. Each lot will connect directly from their lot to a publicly maintain sewer system adjacent to their lot. If there is no public sewer system, the owner will be responsible to construct a public sewer system from their lot to the nearest existing public sewer system.
3. If the City has approved a Low Pressure Sanitary System, a plan shall be submitted showing the alignment, force main size with flow calculations, and connection to the existing system. The plan shall be stamped by a registered professional engineer.
4. The design engineer shall be responsible for submitting the plans to all applicable agencies for approval.
5. Low pressure mainlines shall be a minimum of 2-inches, HDPE, SDR 11 with a minimum of 42-inches of cover.
6. Green tracer wire & locate tape shall be installed along with crown of all mains & service stubs in accordance with the most current Oregon Standard Specifications for Construction. Tracer wire shall daylight at all flushing connections, valves, and lateral connections.
7. Flushing Connections shall be installed at the end of each low pressure line and inline every 1,000 feet minimum.
8. Air-Vac valves shall be placed at high points or at 2,000 feet minimum.
9. Line size plug valves shall be installed at all mainline junctures. Mainline valves shall be ductile iron, class 150, flange by flange, and secured to the HDPE main via fused HDPE flange faces.
10. Laterals shall be taken to the property line being served & an E-one, stainless steel check valve assembly installed.
11. Lateral check valve boxes shall be ARMORCAST A6000485 OR FIBERLYTE FL12. (18"-24" depth) Lids shall have a 20k rating unless approved in writing by LCPW. Lids shall be marked "SEWER"
12. All mainlines shall be pressure tested prior to acceptance by Lincoln City Public Works. Pressure testing shall be completed in accordance with ODOT standard specifications for HDPE pipe. Pressure testing shall include all laterals & assemblies connected to the main, and maintain 150 psi for 30 minutes with no loss of pressure. If the connection to a pressurized HDPE low-pressure sewer main is required the connection shall be made via an HDPE Electrofusion Saddle. Operations shall be adequately trained for electrofusion and submit certification as requested. Connections to PVC or equivalent force mains shall be via a Stainless Steel Saddle equal to the IPSCO Stainless Steel Saddle (Model SC-2).

**LINCOLN CITY PUBLIC WORKS DEPARTMENT  
DESIGN STANDARDS**

801 SW Hwy 101 – PO Box 50, Lincoln City, OR 97367

Phone: (541) 996-2154 (City Hall General Information)

(541) 996-1013 (Public Works Administration and Inspection Requests)

---

**Private Pump Systems**

13. For residential sanitary sewer systems on low-pressure sewer networks, pre-packaged stations for private single and two family residences shall be the E/ONE WH231 system (*850 gal/day, 237 gal capacity*). Only E-Pumps are allowed. For pumps beyond single family & duplex developments see bullet 17. Detailed specifications available on file with LC PWD.
1. All private plumbing & electrical, including gravity sewer, private sewer pumps lines, and panel wiring, shall be completed & permitted within applicable electrical & plumbing codes prior to the start of work.
2. All E-one lateral & pump systems shall be separated from the public mainline by an Environment One, Stainless steel combination ball & check valve assembly (*See #NA0330P02 from E-One*). If not placed at the property line, the assembly shall be placed between the reservoir and public check valve.
3. Pump & reservoir installation shall be completed in accordance with the manufacturer's installation instructions, including but not limited to: tank placement, ballast installation, pipe penetrations, & panel installation. Proof of proper installation and warranty certification from the manufacturer's local representative shall be required prior to acceptance by LCPW.
4. The owner shall submit a site plan showing the location of the existing septic tank, new pump, alarm panel, and the pressure line to the public system.
5. The owner will install the system to City's Standard and be responsible for maintenance of the system except for the pump. The City will maintain the pump.
14. The pump station tank shall be made of a polyethylene or high density polyethylene material. FRP tanks shall be considered only in special circumstances and shall require additional engineering analysis submitted by the applicant.
15. The owner shall install an Alarm Panel equal or more enhanced than the E-One Sentry Alarm Panel-Protect Package.
16. The owner will be required to enter into an agreement that grant to the City access to their property in order to maintain the pump. This agreement shall also outline the owner's responsibility to maintain the other components of their on-site pressure pump system and the electricity needed to run the pump.
17. For E-One pump systems proposed on developments beyond a single family or duplex dwelling an engineering report, prepared and stamped by a registered professional engineer, shall be submitted demonstrating adequate pump & reservoir sizing. Multi-unit pump system control alarms shall additionally be connected into the city's SCATA radio communication system.
18. The owner shall schedule inspections with the City for the inspection of the pump station and force main.
19. The minimum force main from the pump to the public sewer system shall be 1 ¼-inch high density polyethylene SDR 11 solid weld pipe with approved fittings. The pipe bedding shall be a minimum of 4-inches of ¾"-0 or sand.

## CHAPTER 5 - STREETS

### **General Permit Requirements**

1. Design Standards shall govern local design and installation requirements for street construction. Additional design and construction requirements for new streets associated with land development are found in LC Code Sections 16.12 & 16.16. If not indicated in this information, the Oregon Standard Specifications and Oregon Standard Drawings shall apply unless otherwise noted by the LC PWD.
2. Upon request of the LC PWD, owner or his agent shall furnish certification(s) for all materials incorporated into the construction. Certification must include specific material information that will indicate conformance to City requirements, including but not limited to, catalog cuts, test reports, etc.
3. The owner or his agent must request advance permission from LC PWD for any public street closure or lane restriction. A minimum 5-business day notice shall be provided prior to the actual need for street closure or lane restriction. LC PWD must receive with the request a traffic control plan, narrative work statement, a schedule of work activities and other pertinent information to support the need for and timing for the closure/restriction. LC PWD will review request and, upon finding adequate justification, permit the restriction/closure. Permission may include additional requirements if warranted for public safety. Owner or their agent shall notify the Lincoln City Police Department & LC PWD of any street or lane closures 24 hours prior to construction resulting in restriction/closure. LC PWD will monitor periodically during time of restriction/closure and notify owner of any problems requiring attention.
4. Compaction of new street construction is required. Subgrade, crushed rock and asphalt concrete pavement compaction shall be achieved to a minimum of 95-percent of the maximum density as determined by ASTM D1557, Modified Proctor or other applicable standard. Compaction testing shall be provided at a minimum frequency of one (1) test per 3,000 SF of surface area per lift. Owner or his agent shall provide a qualified compaction testing individual/firm to conduct & certify compaction tests. LCPWD may request additional compaction testing or proofrolling of specific areas appearing to not meet minimum compaction requirements. Failed compaction tests shall cause re-compaction or other measures to be taken in the vicinity of the failed test and retesting.
5. LCPWD inspection of street construction is required. Owner or his agent shall provide minimum 48-hour notice to LCPWD of each street construction completion point. Inspections shall occur at point of subgrade completion, crushed rock placement completion, asphalt pavement placement completion. LCPWD may provide periodic inspection during street construction in addition to these required inspection points.
6. The owner or his agent shall provide compaction test results in writing, showing who performed the testing, description of material tested, location/depth, passing requirements and test results. Compaction test results shall be submitted to the LCPWD within five (5) working days after testing.
7. The owner or his agent shall call for LCPWD inspection prior to any curb, curb & gutter, or sidewalk pour. Provide minimum 48-hour notice to LCPWD.
8. Concrete washout stations and/or designated, contained concrete washout areas shall be provided on-site for all construction sites prior to installation of any PCC.

**LINCOLN CITY PUBLIC WORKS DEPARTMENT  
DESIGN STANDARDS**

801 SW Hwy 101 – PO Box 50, Lincoln City, OR 97367

Phone: (541) 996-2154 (City Hall General Information)

(541) 996-1013 (Public Works Administration and Inspection Requests)

---

Inspection/Testing Notification

- Advance coordination & approval required for street closure/lane restriction, provide 5 business day notice to LC PWD
- Owner or his agent shall notify the Lincoln City Police Department & LC PWD of any street or lane closures 24 hours-prior to construction resulting in restriction/closure.
- Street construction inspection, provide 48 hour notice to LC PWD. Inspections shall occur at point of subgrade completion, crushed rock placement completion, asphalt pavement placement completion.
- LC PWD will make periodic general inspections of work in progress, notice of problems will be provided to owner or his agent as necessary
- Follow up problem correction by the owner or his agent upon notice by LC PWD; failure to correct problems in timely manner may result in a finding by LC PWD of violation
- Compaction test results shall be submitted in writing to the LCPWD within five (5) working days after testing.
- The owner or his agent shall call for LCPWD inspection prior to any curb, curb & gutter, or sidewalk pour. Provide minimum 48-hour notice to LC PWD.
- Final street construction inspection, provide 48-hour notice to LC PWD

**Design Standards**

Street design shall be determined based on the Functional Classifications determined by the 2015 Lincoln City Transportation System Plan. (*See Figure 12 in Appendix*) Based on this classification, the “optimal roadway design” subsequently outlined in the TSP will be adopted.

**Street Profile**

Street profiles shall be designed with a maximum grade of 8.3% to accommodate wheelchair users whenever topographical constraints, as determined by the City Engineer, is not a limiting condition.

Where topography is determined to be a constraint, the street profile shall be designed not exceed 12% maximum grade. Grades of up to 15% maximum are allowed for no more than 150-feet.

**Centerline Radius**

The topography of Lincoln City is mountainous. For design purposes the following minimum centerline radii should be used based on street classification;

Alley or Local	120 feet
Collector	200 feet
Arterial	300 feet

**Right of Way**

The minimum right-of-way required for city streets is;

Low Use Local Street	40 feet
Medium and High Use Local Streets	45 feet

**LINCOLN CITY PUBLIC WORKS DEPARTMENT  
DESIGN STANDARDS**

801 SW Hwy 101 – PO Box 50, Lincoln City, OR 97367

Phone: (541) 996-2154 (City Hall General Information)

(541) 996-1013 (Public Works Administration and Inspection Requests)

---

Low Use Collector Street	50 feet
Medium and High Use Collector Street	55 feet
Arterial street	60 feet

**Subgrade**

Geotechnical testing must be performed by a licensed professional to establish the suitability and load bearing capacity of soils within the proposed street alignment.

Developer shall provide copies of all geotechnical reports, test results, and calculations to the Department of Public Works with the plan submittal.

**Roadway Section**

The roadway section shall be designed by a licensed professional engineer registered within the State of Oregon using the subgrade geotechnical information obtained by testing.

The roadway section shall consist of the following components:

- Roadway fabric
- Base Rock
- Leveling Rock
- Asphalt Mix

**Asphalt Concrete Paving (ACP)**

Paving shall be 4-inch minimum compacted depth Level II HMAC ½ inch dense grade to 92% minimum density. Paving shall be per most current edition of the ODOT/APWA Standards, Section 00744 & Section 00745 for Hot Mix Asphalt Concrete (HMAC) inclusive of all requirements.

Roadway trench patches shall be “T-cut” style trench repair. Repair shall place 4” minimum of HMAC per ODOT Standard drawing RD302

All existing pavement shall be vertically cut & a clean edge prepared for the abutting of new ACP placement. All joints shall be tack sealed to prevent the entry of moisture and pavement deterioration.

**Cross Slope**

- Local Access streets shall have a cross-slope of 3.0%.
- Collectors and Arterials shall have a cross-slope of 2.0% minimum.

**Street Cross Section**

- Local streets;
  - 10 feet minimum travel lanes
  - 5 or 6 feet minimum sidewalks

- Collector streets
  - 12 feet minimum travel lanes
  - 5 to 6 feet minimum sidewalks
  - 5 to 6 feet bike lanes

**LINCOLN CITY PUBLIC WORKS DEPARTMENT  
DESIGN STANDARDS**

801 SW Hwy 101 – PO Box 50, Lincoln City, OR 97367

Phone: (541) 996-2154 (City Hall General Information)

(541) 996-1013 (Public Works Administration and Inspection Requests)

---

All streets shall provide a minimum of 20-foot unobstructed travel way without exception.

**Curb Returns**

Curb returns shall be a minimum of:

Local to local	15 feet
Local to Collector or Arterial	20 feet
Collector to Collector or Arterial	25 feet
Arterial to Arterial	30 feet

**Curb and Gutter**

Curb and Gutter shall be constructed per the most current edition of the ODOT/APWA Standard Specifications, Section 00480 Drainage Curbs. Curb and Gutter shall be used within the public right-of-way and replace Type C straight curb within project limits. Gutter pan shall be 18-inches width and be sloped at 0.25% minimum along flow line. See ODOT standard drawing RD700.

**Side Slopes**

Side slopes from the edge of shoulder shall not exceed 3:1 slope for a minimum distance of 5 feet. Side slopes beyond 5 feet from shoulder may have a maximum grade of 2:1 without geotechnical engineering calculations showing a steeper grade to be stable.

**Sight Distance**

Sight distance at accesses and intersections will be required per AASHTO geometric design standards utilizing the Design Speeds table provided below. Sight standard to be used will be from assumed driver's eye level (3.5-feet) to approaching vehicle headlight level (2.5-feet).

Sight distance for horizontal and vertical curves shall conform to AASHTO geometric design standards utilizing the Design Speeds provided above. Sight standard to be used will be from assumed driver's eye level (3.5-feet) to an object 6-inches in height.

If all intersection legs are 'stop' sign controlled, the 50-foot clear vision triangle default may be used as Appropriate.

Sight distance analysis calculations, including crossing calculations, by the design engineer must be submitted to the Public Works Department with the plans in compliance with LCMC 17.52.060.

**Pavement Markings**

All paint striping for streets shall be reflective latex and applied per the most current edition of the Manual of Uniform Traffic Control Devices.

Cross Walks shall be reflective thermo-plastic applied in 2-foot wide by 8-foot long panels spaced 6-foot on-center. Panels shall be aligned lengthwise with traffic and placed outside of the wheel paths.

Lane Markings (turn arrows, bike symbols, etc.) shall be reflective thermo-plastic and applied per the most current edition of the Manual of Uniform Traffic Control Devices.

**LINCOLN CITY PUBLIC WORKS DEPARTMENT  
DESIGN STANDARDS**

801 SW Hwy 101 – PO Box 50, Lincoln City, OR 97367

Phone: (541) 996-2154 (City Hall General Information)

(541) 996-1013 (Public Works Administration and Inspection Requests)

---

Reflectors shall be applied per the most current edition of the Manual of Uniform Traffic devices.

**Accessible Ramps**

Each roadway corner shall be considered an intersection & require an ADA compliant curb ramp unless otherwise determined by LCPW.

Handicap Ramps shall be located at the half delta of curb returns and ends of sidewalks per the most current edition of the Oregon Standard Drawings, Details RD756 & RD757.

A temporary asphalt ramp, landing, and tapered shoulder shall be constructed at the terminus of any sidewalk ending above existing grade. See Oregon Standard Drawings, detail RD754.

Tactile Warning Dome panels shall be yellow in color and placed flush with the back of curb or as close as possible when prohibited by curb return radii.

**Street Signs**

Street signs shall be located at the back of sidewalk.

Signs limited to placement within the sidewalk shall be provided with a 12" minimum diameter PVC sleeve through the concrete set at the back of curb and flush with sidewalk grade.

The signpost will be placed centered within the sleeve and backfilled with ¾" minus crushed rock to grade.

Posts shall be 4"x4" pressure treated lumber.

Signs shall conform to the most current edition of the Manual of Uniform Traffic Control Devices.

**Residential Driveways**

Residential driveways shall be located 100 feet from intersections or the maximum distance available on the property. Driveways shall not be located closer than 30 feet from any intersection, alley, or crosswalk.

Driveway width, excluding transition ramps, for residential lots shall conform to the following;

Single lane residential: 10 feet min. / 15' max.

Double lane residential: 20 feet min. / 24' max.

Driveway length shall be a minimum of 20' from back of sidewalk if outside of right-of-way, or from property line to face of garage.

Driveway grades shall be designed with a minimum of 2 feet rounding from back of sidewalk or street edge to a maximum 15 percent slope. Parking areas attached to or part of driveways shall not exceed 6 percent slope in any direction.

**LINCOLN CITY PUBLIC WORKS DEPARTMENT  
DESIGN STANDARDS**

801 SW Hwy 101 – PO Box 50, Lincoln City, OR 97367

Phone: (541) 996-2154 (City Hall General Information)

(541) 996-1013 (Public Works Administration and Inspection Requests)

---

**Driveway approaches**

Commercial approaches shall be:

- 'Fully Depressed' style with maximum of 2% cross-slope per ADA requirements. Wings shall be a minimum of 6-feet in length. Refer to most current edition of the Oregon Standard Drawings, Detail RD735 Option G.

Residential approaches shall be either:

- 'Curb Drop' style with a minimum 4-foot wide 'pathway' with a maximum of 2% cross-slope per ADA requirements from the back of sidewalk. Driveway apron will then extend to face of curb. Refer to most current edition of the Oregon Standard Drawings, Detail RD730, Option D
- OR 'Fully Depressed' style with a maximum of 2% cross-slope per ADA requirements from the back of sidewalk. Refer to most current edition of the Oregon Standard Drawings, Detail RD735, Option G.

Minimum driveway approach width shall be:

- 10-feet for single family residences / single car garage.
- 20-feet for duplexes / two car garage.
- 24-feet for commercial building unless otherwise directed by City or, if fronting on Highway 101, Oregon Department of Transportation comment.

Maximum driveway approach width shall be:

- 15-feet for single family residences / single car garage.
- 24-feet for duplexes / two car garage. .
- 30-feet for commercial building unless otherwise directed by City or, if fronting on Highway 101, Oregon Department of Transportation comment.

**Sidewalks**

Sidewalk design shall be determined by the “functional classification” of the roadway. Sidewalks shall be a minimum 6 feet in width from back of curb on local and collector streets, unless otherwise directed by the city engineer.

Sidewalks to be used for combined bicycle and pedestrian use shall be a minimum of 10 feet in width.

Cross slope on sidewalks shall not exceed 2% per the American Disabilities Act and shall not be less than 0.5%. Cross slope will be verified “as-built” at the final inspection. Owner or his agent will be responsible for repairing or replacing sidewalks with greater than 2% cross slope.

Profile of sidewalks within a right of way or along a street the grade of pedestrian access route shall not exceed the general grade established for the adjacent street or highway.

Where sidewalks depart from the street or right-of-way the grade shall not exceed 5%. For slopes between 5% & 8.3% 'refuge' landings shall be spaced appropriately, every 50 feet.

NOTES:

1. WHEN RAINFALL AND RUNOFF OCCURS, A KNOWLEDGEABLE AND EXPERIENCED PERSON IN THE PRINCIPLES, PRACTICES, INSTALLATION, AND MAINTENANCE OF EROSION AND SEDIMENT CONTROLS WHO WORKS FOR THE GENERAL CONTRACTOR MUST PROVIDE DAILY INSPECTIONS OF THE EROSION AND SEDIMENT CONTROLS AND DISCHARGE OUTFALLS.
2. OWNER OR DESIGNATED PERSON SHALL BE RESPONSIBLE FOR PROPER INSTALLATION AND MAINTENANCE OF ALL EROSION AND SEDIMENT CONTROL MEASURES, IN ACCORDANCE WITH CURRENT LINCOLN CITY AND STATE, AND FEDERAL REGULATIONS.
3. CONSTRUCTION ACTIVITIES MUST AVOID OR MINIMIZE EXCAVATION AND CREATION OF BARE GROUND FROM OCTOBER 1 THROUGH MAY 31ST EACH YEAR.
4. DURING WET WEATHER PERIOD, TEMPORARY STABILIZATION OF THE SITE MUST OCCUR AT THE END OF EACH WORK DAY.
5. ALL EXPOSED SOILS MUST BE COVERED DURING WET WEATHER PERIOD. (SEE DETAIL LCPW E&SC 150, 165) FOR FILL PILE. PRIOR TO ANY LAND DISTURBING ACTIVITIES, THE BOUNDARIES OF THE CLEARING LIMITS, VEGETATED BUFFERS, AND ANY SENSITIVE AREAS SHOWN ON THIS PLAN SHALL BE CLEARLY DELINEATED IN THE FIELD. UNLESS OTHERWISE APPROVED, NO DISTURBANCE IS PERMITTED BEYOND THE CLEARING LIMITS. THE OWNER/PERMITTEE MUST MAINTAIN THE DELINEATION FOR THE DURATION OF THE PROJECT. NOTE: VEGETATED CORRIDORS TO BE DELINEATED WITH ORANGE CONSTRUCTION FENCE OR APPROVED EQUAL.
6. PRIOR TO ANY LAND DISTURBING ACTIVITIES, THE BMPS THAT MUST BE INSTALLED ARE GRAVEL CONSTRUCTION ENTRANCE, PERIMETER SEDIMENT CONTROL, AND INLET PROTECTION. THESE BMPS MUST BE MAINTAINED FOR THE DURATION OF THE PROJECT.(SEE DETAIL LCPW E&SC - 110, 115, 120, 130, 135, 140, 145) SEDIMENT CONTROLS SUCH AS CHECK DAMS, MATS, WATTLES, SED FENCES MUST BE INSTALLED AND MAINTAINED ON ALL DOWN GRADIENT SIDES OF THE CONSTRUCTION SITE AT ALL TIMES DURING CONSTRUCTION. THEY MUST REMAIN IN PLACE UNTIL PERMANENT VEGETATION OR OTHER PERMANENT COVERING OF EXPOSED SOIL IS ESTABLISHED. ( SEE LCPW DET - 115, 125, 150,155,160,170)
7. ALL ACTIVE INLETS MUST HAVE SEDIMENT CONTROLS INSTALLED AND MAINTAINED AT ALL TIMES DURING CONSTRUCTION. UNLESS OTHERWISE APPROVED, A SURFACE MOUNTED AND ATTACHABLE, U-SHAPED FILTER BAG IS REQUIRED FOR ALL CURB INLET CATCH BASINS. (SEE DETAIL LCPW E&SC - 135, 140, 145)
8. SIGNIFICANT AMOUNTS OF SEDIMENT THAT LEAVES THE SITE MUST BE CLEANED UP WITHIN 24 HOURS AND PLACED BACK ON THE SITE AND STABILIZED OR PROPERLY DISPOSED. THE CAUSE OF THE SEDIMENT RELEASE MUST BE FOUND AND PREVENTED FROM CAUSING A RECURRENCE OF THE DISCHARGE WITHIN THE SAME 24 HOURS. ANY IN-STREAM CLEAN UP OF SEDIMENT SHALL BE PREFORMED ACCORDING TO THE OREGON DEPARTMENT OF STATE LANDS REQUIRED TIME FRAME.
9. SEDIMENT MUST NOT BE INTENTIONALLY WASHED INTO STORM SEWERS, DRAINAGE WAYS, OR WATER BODIES.
10. SEDIMENT MUST BE REMOVED FROM BEHIND ALL SEDIMENT CONTROL MEASURES WHEN IT HAS REACHED A HEIGHT OF 1/3-RD THE BARRIER HEIGHT AND PRIOR TO THE CONTROL MEASURES REMOVAL.
11. CLEANING OF ALL STRUCTURES WITH SUMPS MUST OCCUR WHEN THE SEDIMENT RETENTION CAPACITY HAS BEEN REDUCED BY 50% AND AT COMPLETION OF PROJECT.
12. ANY USE OF TOXIC OR OTHER HAZARDOUS MATERIALS MUST INCLUDE PROPER STORAGE, APPLICATION, AND DISPOSAL.
13. THE PERMITTEE MUST PROPERLY MANAGE HAZARDOUS WASTES, USED OILS, CONTAMINATED SOILS, CONCRETE WASTE, SANITARY WASTE, LIQUID WASTE, OR OTHER TOXIC SUBSTANCES DISCOVERED OR GENERATED DURING CONSTRUCTION.
14. THE APPLICATION RATE OF FERTILIZERS USED TO REESTABLISH VEGETATION MUST FOLLOW MANUFACTURER'S RECOMMENDATIONS. NUTRIENT RELEASES FROM FERTILIZERS TO SURFACE WATERS MUST BE MINIMIZED. TIME RELEASE FERTILIZERS SHOULD BE USED AND CARE SHOULD BE MADE IN APPLICATION OF FERTILIZERS WITHIN ANY WATER WAY RIPARIAN ZONE.
15. IF VEGETATIVE SEED MIXES ARE SPECIFIED, SEEDING MUST TAKE PLACE NO LATER THAN SEPTEMBER 1ST; THE TYPE AND PERCENTAGES OF SEED IN THE MIX ARE AS IDENTIFIED ON THE PLANS OR AS SPECIFIED BY THE DESIGN ENGINEER.
16. WATERTIGHT TRUCKS MUST BE USED TO TRANSPORT SATURATED SOILS FROM THE CONSTRUCTION SITE. AN APPROVED EQUIVALENT IS TO DRAIN THE SOIL ON SITE AT A DESIGNATED LOCATION USING APPROPRIATE BMPS; SOIL MUST BE DRAINED SUFFICIENTLY FOR MINIMAL SPILLAGE.
17. ALL PUMPING OF SEDIMENT LADEN WATER MUST BE DISCHARGED OVER AN UNDISTURBED, PREFERABLY VEGETATED AREA, AND THROUGH A SEDIMENT CONTROL BMP (I.E. FILTER BAG).
18. THE ESC PLAN MUST BE KEPT ONSITE. ALL MEASURES SHOWN ON THE PLAN MUST BE INSTALLED PROPERLY TO ENSURE THAT SEDIMENT LADEN WATER DOES NOT ENTER A SURFACE WATER SYSTEM, ROADWAY, OR OTHER PROPERTIES.
19. THE ESC MEASURES SHOWN ON THIS PLAN ARE THE MINIMUM REQUIREMENTS FOR ANTICIPATED SITE CONDITIONS. DURING THE CONSTRUCTION PERIOD, THESE MEASURES SHALL BE UPGRADED AS NEEDED TO MAINTAIN COMPLIANCE WITH ALL REGULATIONS.
20. WRITTEN ESC LOGS ARE SUGGESTED TO BE MAINTAINED ONSITE AND AVAILABLE TO DISTRICT INSPECTORS UPON REQUEST.
21. IN AREAS SUBJECT TO WIND EROSION, APPROPRIATE BMPS MUST BE USED WHICH MAY INCLUDE THE APPLICATION OF FINE WATER SPRAYING, PLASTIC SHEETING, MULCHING, OR OTHER APPROVED MEASURES.

## STANDARD EROSION CONTROL NOTES FOR CONSTRUCTION SITES LESS THAN 1 ACRE

DETAIL: 100 - LCPW E&SC Standard Notes

REVISED: APRIL 2019



FOR FURTHER INFORMATION  
ON DESIGN CRITERIA SEE  
CHAPTER 4 OF CLEAN WATER  
SERVICES EROSION PREVENTION  
AND SEDIMENT CONTROL  
PLANNING AND DESIGN MANUAL.

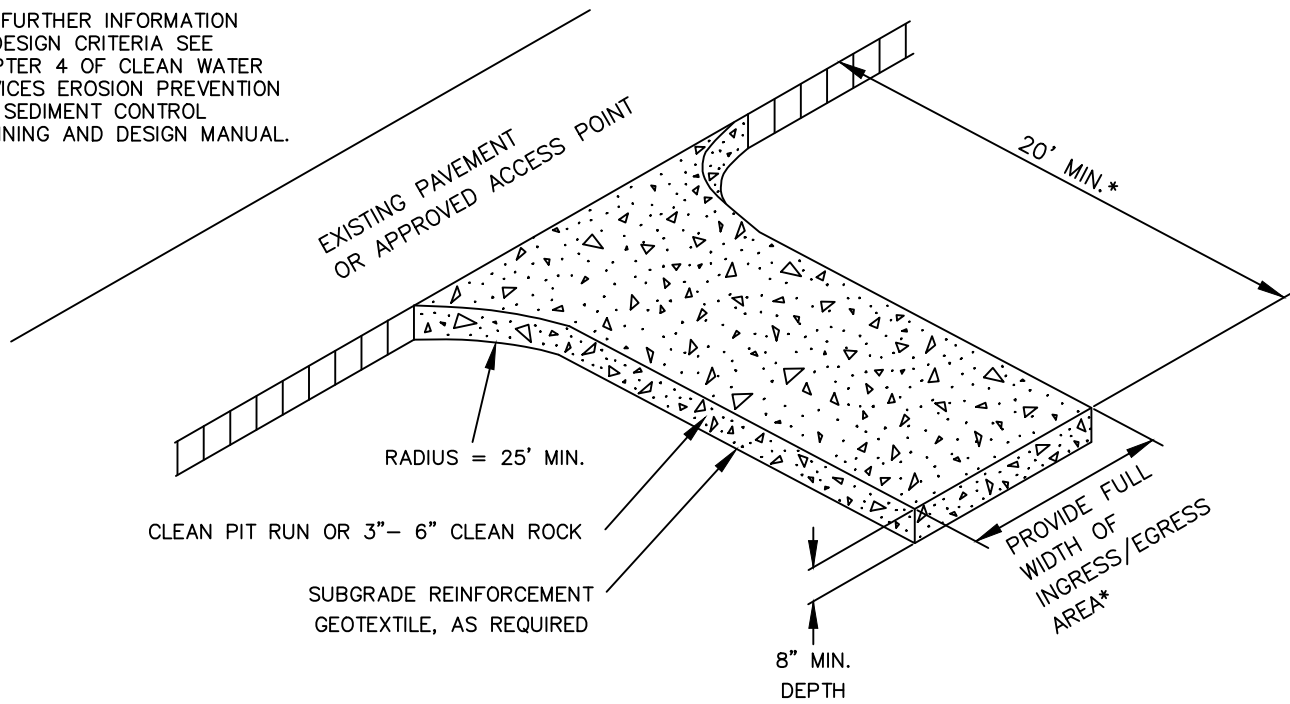

\*20' MIN. FOR SINGLE FAMILY AND DUPLEX RESIDENTIAL. 50'  
MINIMUM FOR COMMERCIAL AND INDUSTRIAL CONSTRUCTION SITES

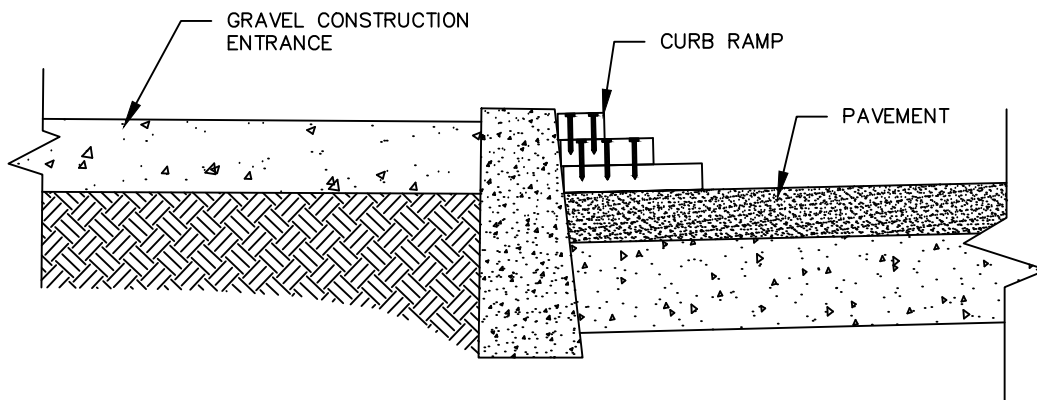

NOTES:

1. THE ENTRANCE SHALL BE MAINTAINED IN A CONDITION THAT WILL PREVENT TRACKING OR FLOWING OF SEDIMENT ONTO PUBLIC RIGHT-OF-WAYS. THIS MAY REQUIRE TOP DRESSING, REPAIR AND/OR CLEAN OUT OF ANY MEASURES USED TO TRAP SEDIMENT.
2. WHEN NECESSARY, WHEELS SHALL BE CLEANED PRIOR TO ENTRANCE ONTO PUBLIC RIGHT-OF- WAY.
3. WHEN WASHING IS REQUIRED, IT SHALL BE DONE ON AN AREA STABILIZED WITH CRUSHED STONE THAT DRAINS INTO AN APPROVED SEDIMENT TRAP OR SEDIMENT BASIN.
4. WHERE RUNOFF CONTAINING SEDIMENT LADEN WATER IS LEAVING THE SITE VIA THE CONSTRUCTION ENTRANCE, OTHER MEASURES SHALL BE IMPLEMENTED TO DIVERT RUNOFF THROUGH AN APPROVED FILTERING SYSTEM.
5. DIMENSIONS  
SINGLE FAMILY  
 20' LONG BY 20' WIDE 8" DEEP OF 3/4" MINUS CLEAN ROCK.  
COMMERCIAL  
 50' LONG BY 20' WIDE 3-6" CLEAN ROCK, GOVERNING AUTHORITY MAY REQUIRE GEOTEXTILE FABRIC TO PREVENT SUB-SOIL PUMPING.

**CONSTRUCTION ENTRANCE  
GRAVEL**

DETAIL-110 LCPW E&SC

REVISED: APRIL 2019



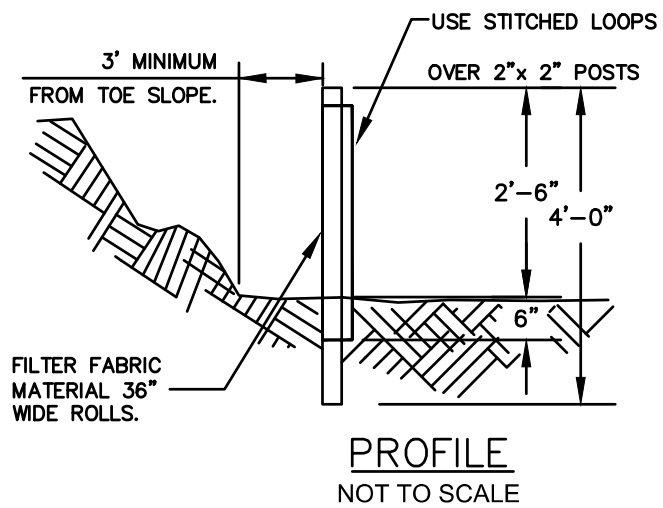
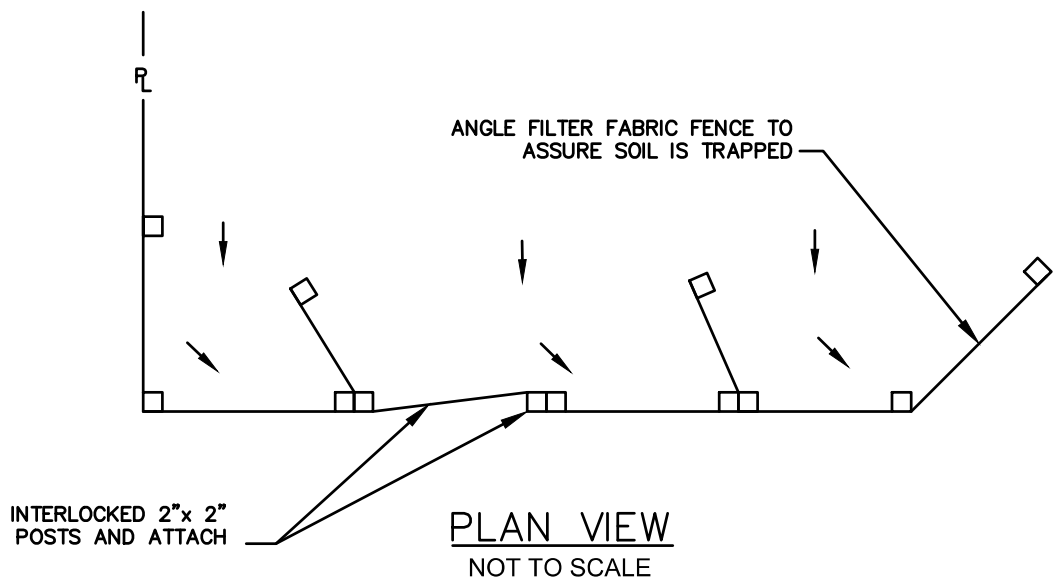

**NOTES:**

1. BURY BOTTOM OF FILTER FABRIC 6" VERTICALLY BELOW FINISHED GRADE.
2. 2"x 2" FIR, PINE OR STEEL FENCE POSTS.
3. POSTS TO BE INSTALLED ON UPHILL SIDE OF SLOPE.
4. COMPACT BOTH SIDES OF FILTER FABRIC TRENCH.
5. PANELS MUST BE PLACED ACCORDING TO SPACING ON DETAIL NO.940

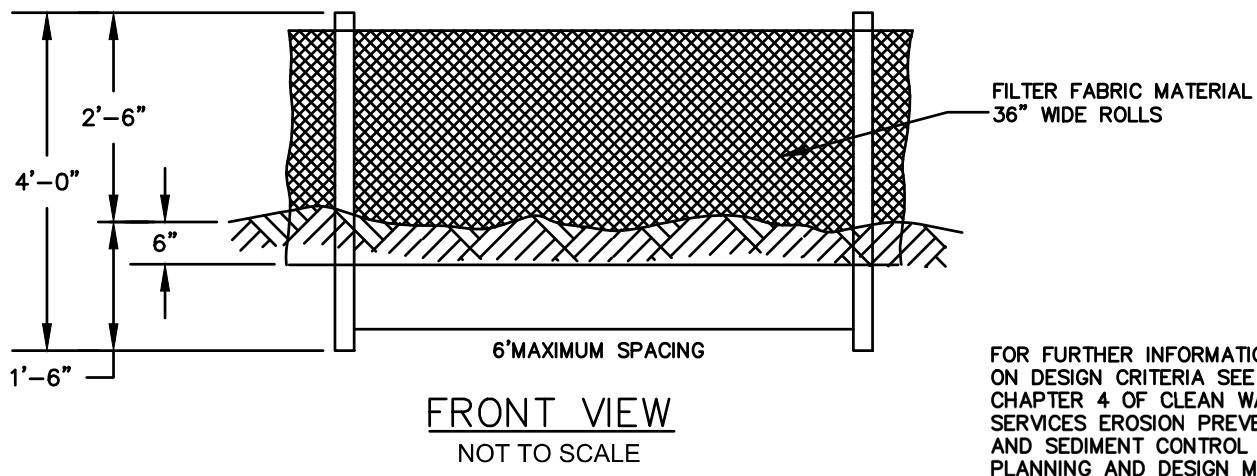

FOR FURTHER INFORMATION ON DESIGN CRITERIA SEE CHAPTER 4 OF CLEAN WATER SERVICES EROSION PREVENTION AND SEDIMENT CONTROL PLANNING AND DESIGN MANUAL.

**LCPW STANDARD SILT FENCE**

DETAIL: 115 LCPW E&SC - Silt Fence

REVISED:  
APRIL 2019



FOR FURTHER INFORMATION  
ON DESIGN CRITERIA SEE  
CHAPTER 4 OF CLEAN WATER  
SERVICES EROSION PREVENTION  
AND SEDIMENT CONTROL  
PLANNING AND DESIGN MANUAL.

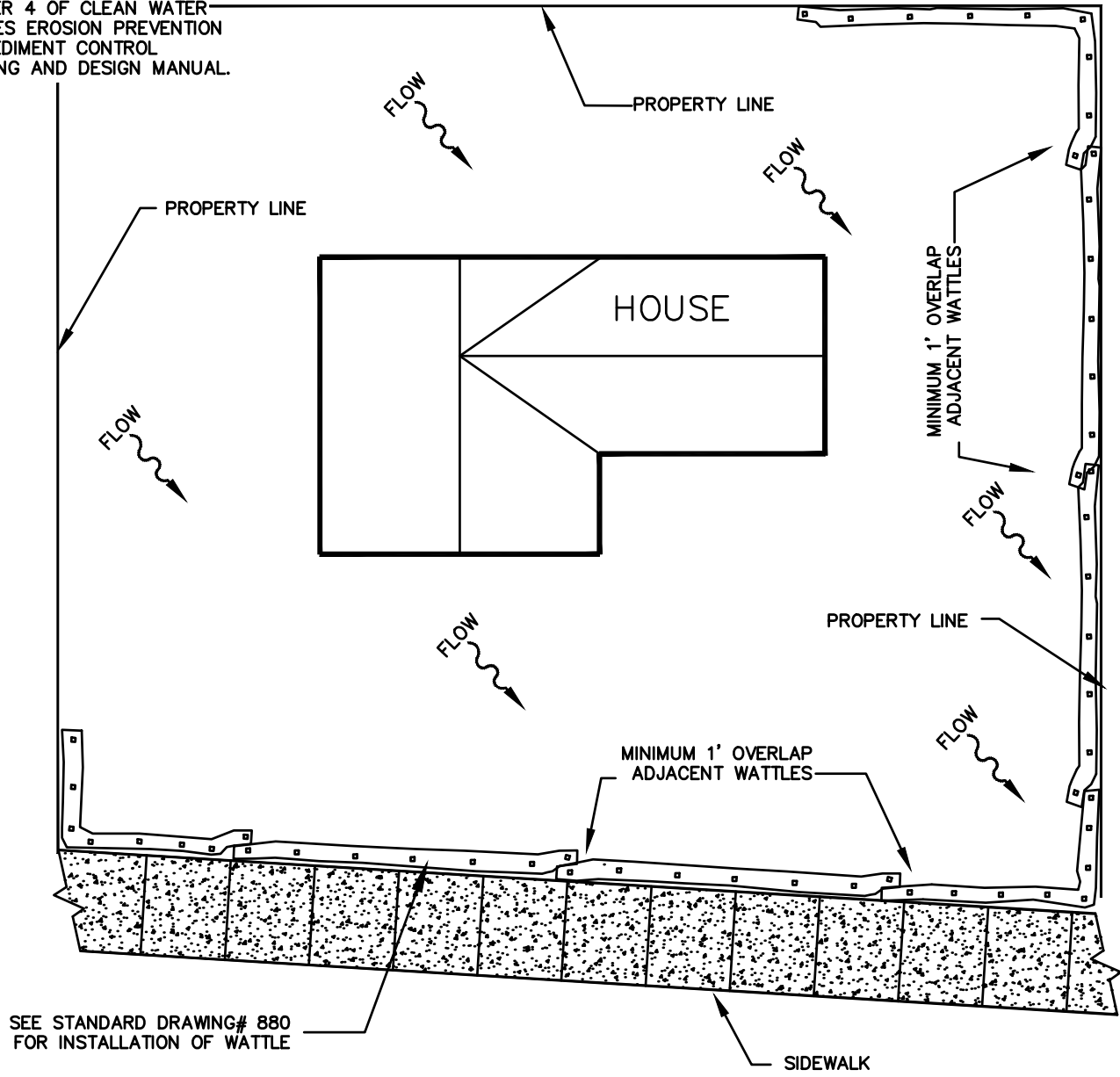

SEE STANDARD DRAWING# 880  
FOR INSTALLATION OF WATTLE

PLAN VIEW  
NTS

NOTES:

1. SEE STANDARD DRAWING 125 LCPW E&SC - WATTLE DETAIL FOR INSTALLATION OF WATTLES.
2. CALL LC PUBLIC WORKS FOR DELIVERY OF STRAW WATTLES AT 541.996.2154
3. ALTERNATE MATERIALS MAY BE USED AS APPROVED BY PUBLIC WORKS.
4. PERIMETER MEASURES INSTALLED AS NEEDED.

**PERIMETER CONTROL - WATTLES**

DETAIL: 120 LCPW E&SC - PERIMETER  
CONTROL WATTLES

REVISED:  
APRIL 2019

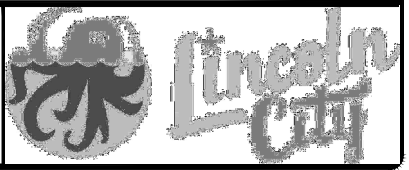

FOR FURTHER INFORMATION  
ON DESIGN CRITERIA SEE  
CHAPTER 4 OF CLEAN WATER  
SERVICES EROSION PREVENTION  
AND SEDIMENT CONTROL  
PLANNING AND DESIGN MANUAL.

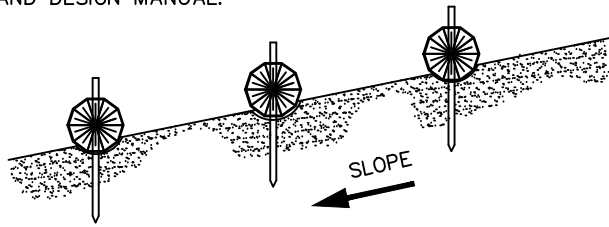

PLACE WATTLES ALONG SLOPE CONTOURS.

PROFILE  
NOT TO SCALE

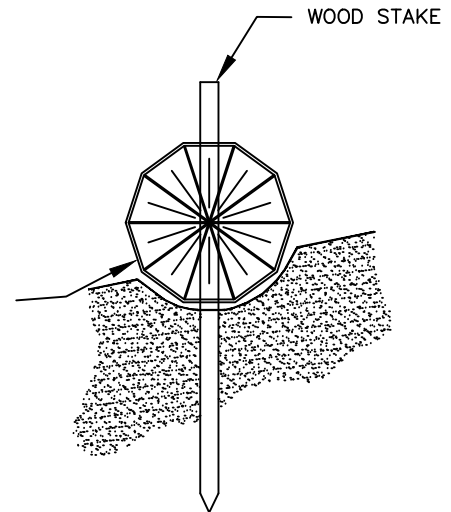

SECTION  
NOT TO SCALE

WHEAT STRAW, RYE  
GRASS STRAW,  
COCONUT OR  
EXCELSIOR WATTLES

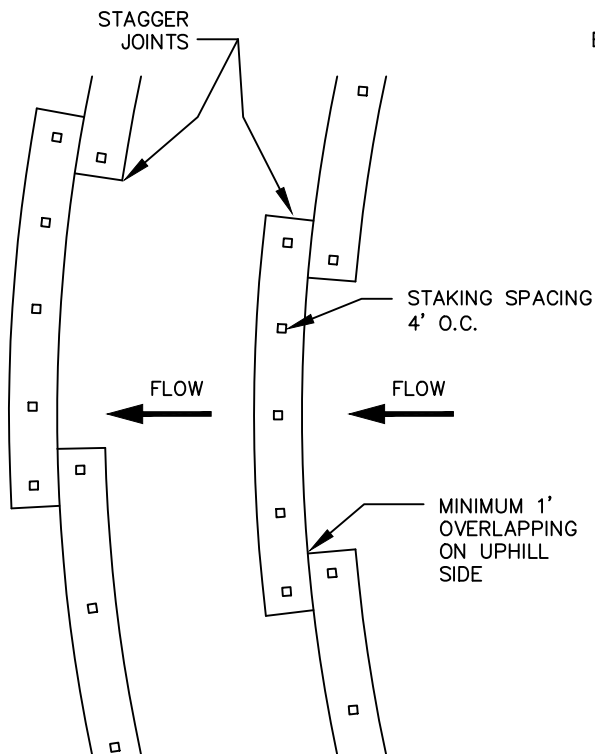

PLAN VIEW  
NOT TO SCALE

NOTES:

1. STAKING SPECIFICATIONS:
  - a. 1"X2" WOODEN STAKES
  - b. ADDITIONAL STAKES MAY BE INSTALLED ON DOWNHILL SIDE OF WATTLES, ON STEEP SLOPE OR HIGHLY EROSIIVE SOILS.
2. SPACING IN ACCORDANCE WITH DETAIL 940.
3. REMOVE ALL ROCKS, CLODS, VEGETATION OR OTHER OBSTRUCTIONS SO THAT THE INSTALLED WATTLES WILL HAVE DIRECT CONTACT WITH THE SOIL.
4. INSTALL THE WATTLES IN A 2" DEEP TRENCH, INSURING THAT NO GAPS EXIST BETWEEN THE SOIL AND THE BOTTOM OF THE WATTLE.. THE ENDS OF ADJACENT WATTLES SHALL BE OVERLAPPED 1 FT. MINIMUM TO PREVENT SEDIMENT PASSING THROUGH THE FIELD JOINT.

**WATTLE INSTALLATION DETAIL**

DETAIL: 125 LCPW E&SC - WATTLE  
INSTALLATION

REVISED:  
APRIL 2019



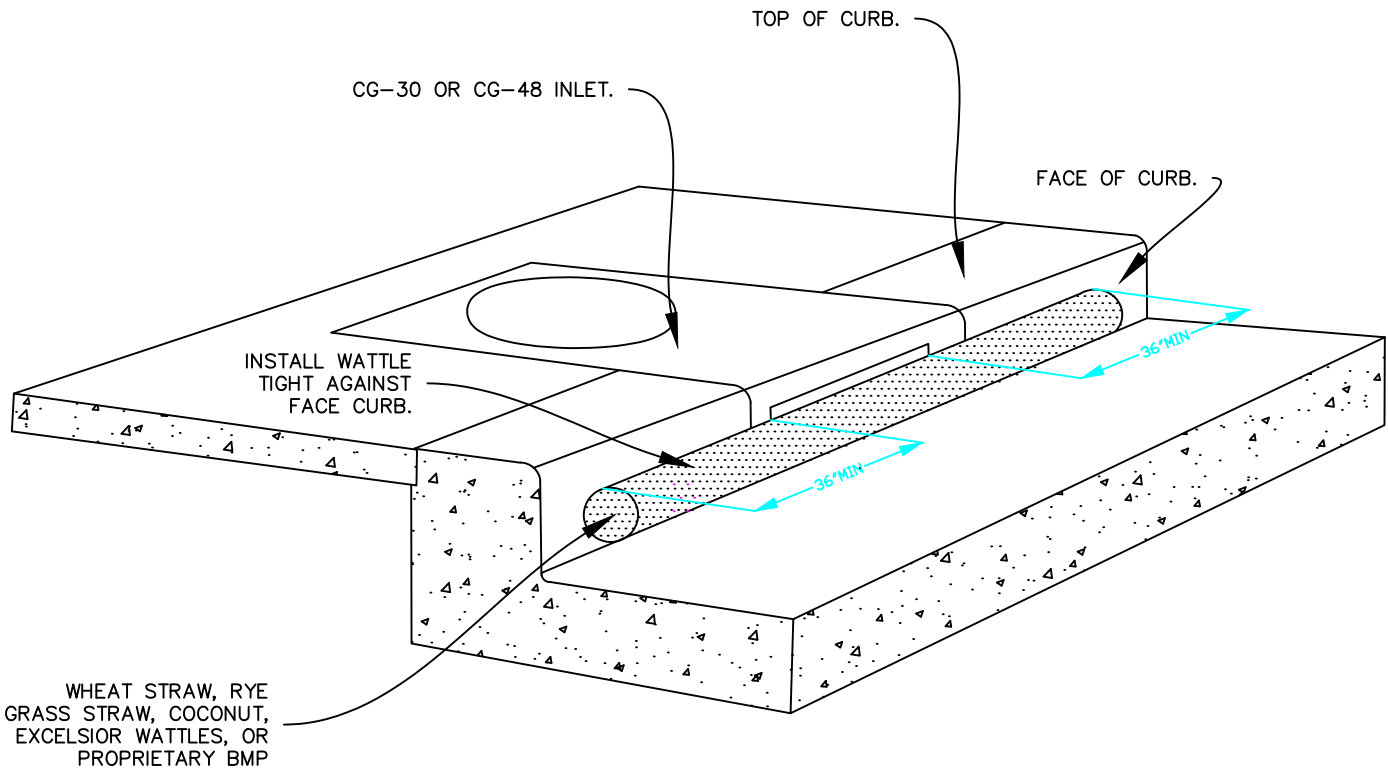

PERSPECTIVE VIEW SHOWING WATTLE  
ALONG GUTTER AT CURB INLET

INSTALLATION NOTES:

1. ONLY ALLOWED USE OF APPLICATION IS ON CG-30 AND CG-48 INLETS UNLESS APPROVED BY CWS.
2. INSTALL WATTLE ALONG INLET WITH WATTLE EXTENDING A MIN OF 36" BEYOND INLET OPENINGS IN EACH DIRECTION.
3. WATTLE MUST BE INSTALLED TIGHTLY AGAINST CURB. MAY REQUIRE ADDITIONAL MEASURES TO ENSURE WATTLE REMAINS TIGHT AGAINST CURB, SUCH AS USING ZIP-TIES TO SECURE WATTLE TO INLET'S TRASH BARS OR USING SANDBAGS TO WEIGHT DOWN WATTLE.

MAINTENANCE NOTES:

1. ANY VISIBLE SIGN OF SEDIMENT ACCUMULATION TO BE CLEANED UP AT THE END OF EACH WORKDAY.
2. REPLACE WATTLE AS NECESSARY TO PREVENT SEDIMENT FROM ENTERING THE STORM SYSTEM.

CURB & GUTTER INLET PROTECTION DETAIL

DETAIL: 130 LCPW E&SC - INLET  
PROTECTION

REVISED:  
APRIL 2019



Lincoln  
City

MAY BE USED SHORT TERM  
W/ UTILITY WORK AND W/  
PHASING OF DEVELOPMENT

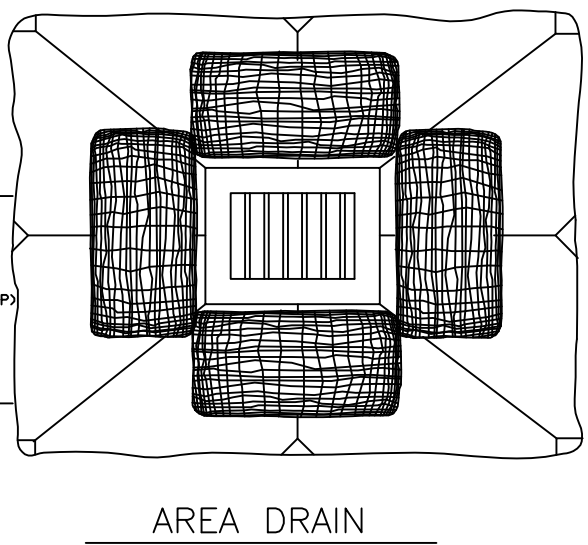
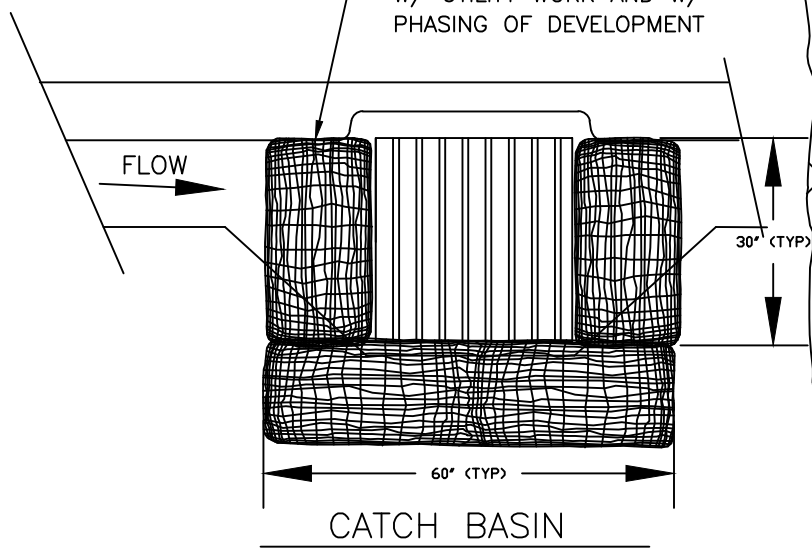

AREA DRAIN

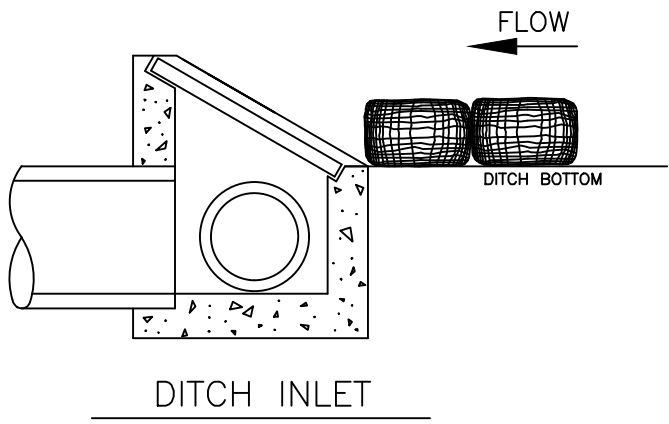

DITCH INLET

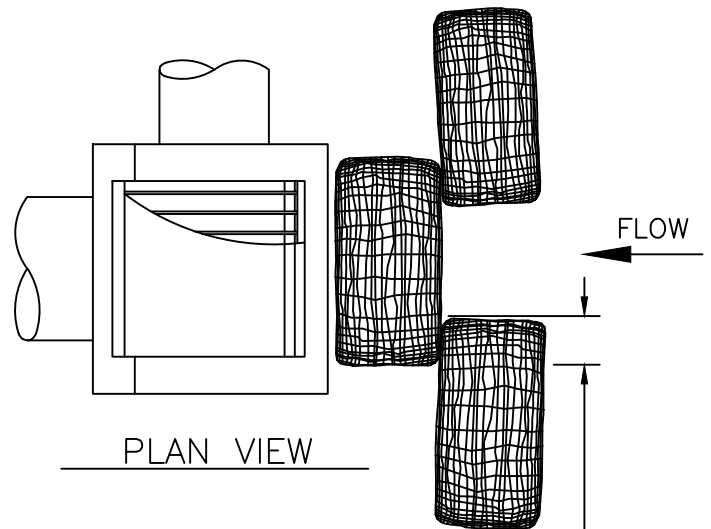

PLAN VIEW

6" overlap of bags.

**NOTES:**

1. ADDITIONAL MEASURES MUST BE CONSIDERED DEPENDING ON SOIL TYPES AND SITE CONDITIONS.
2. BIO-FILTER BAGS SHOULD BE STAKED WHERE APPLICABLE USING (2) 1"x2" WOODEN STAKES OR APPROVED EQUAL PER BAG.
3. WHEN USING 30" BIO-BAGS TO PROTECT A CATCH BASIN YOU MUST HAVE 4 BAGS AND THEY SHALL BE OVERLAPPED BY 6".

FOR FURTHER INFORMATION ON DESIGN CRITERIA SEE CHAPTER 4 OF CLEAN WATER SERVICES EROSION PREVENTION AND SEDIMENT CONTROL PLANNING AND DESIGN MANUAL.

**CATCH BASIN BARRIER PROTECTION**

DETAIL: 135 LCPW E&SC - CATCH BASIN BARRIER PROTECTION I

REVISED: APRIL 2019

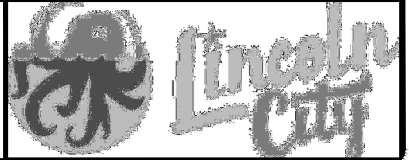

FOR FURTHER INFORMATION  
ON DESIGN CRITERIA SEE  
CHAPTER 4 OF CLEAN WATER  
SERVICES EROSION PREVENTION  
AND SEDIMENT CONTROL  
PLANNING AND DESIGN MANUAL.

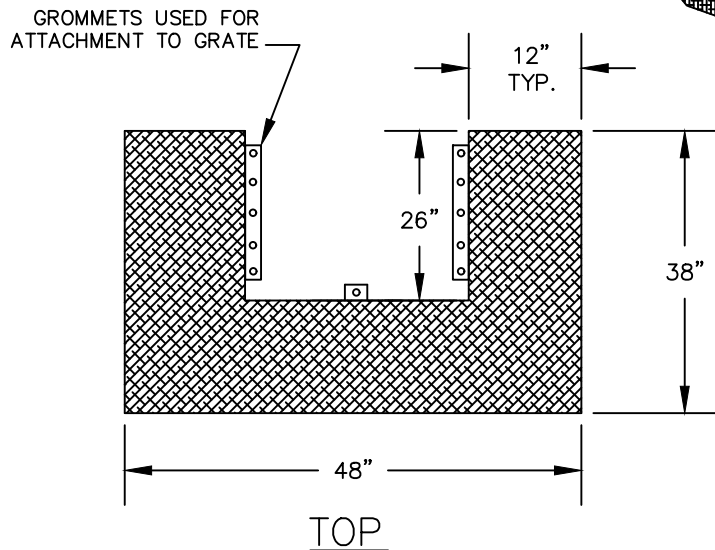
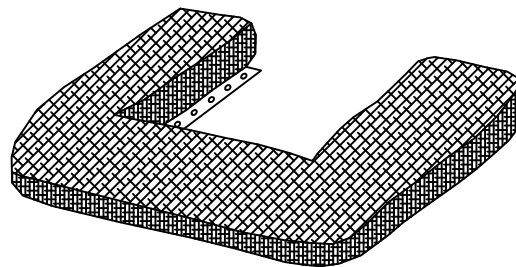
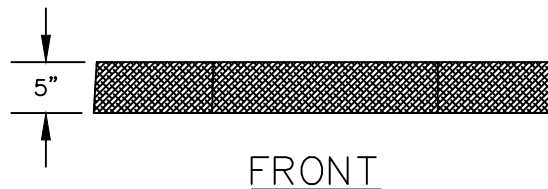
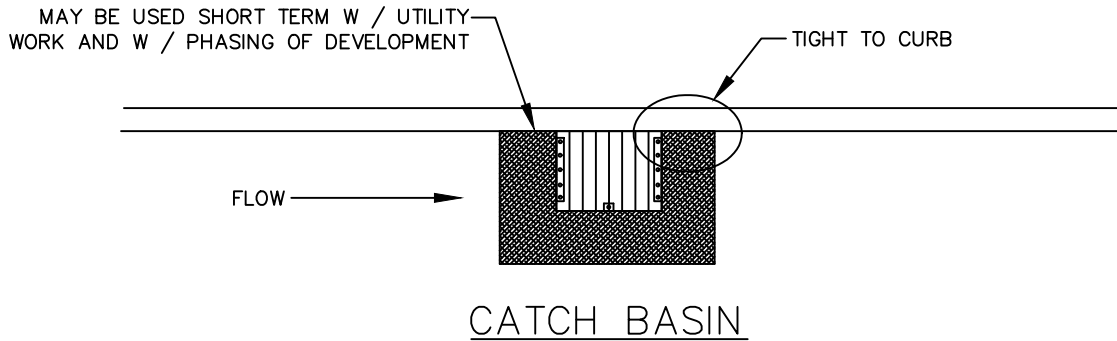

INSTALLATION NOTES:

1. INSTALL SOLID FABRIC SIDE DOWN MESH SIDE UP.
2. ATTACH TO CATCH BASIN GRATE AT A MINIMUM OF 3 LOCATIONS TIGHT TO CURB WITH 1/4" ZIP TIES.

MAINTENANCE NOTES:

1. ANY VISIBLE SIGN OF SEDIMENT ACCUMULATION TO BE CLEANED UP AT THE END OF EACH WORKDAY.
2. REPLACE U - SHAPED FILTER BAG AS NECESSARY TO PREVENT WOOD CHIPS FROM ENTERING THE STORM SYSTEM.

## CATCH BASIN BARRIER PROTECTION II

DETAIL: 140 LCPW E&SC - CATCH BASIN  
PROTECTION

REVISED:  
APRIL 2019



Lincoln  
City

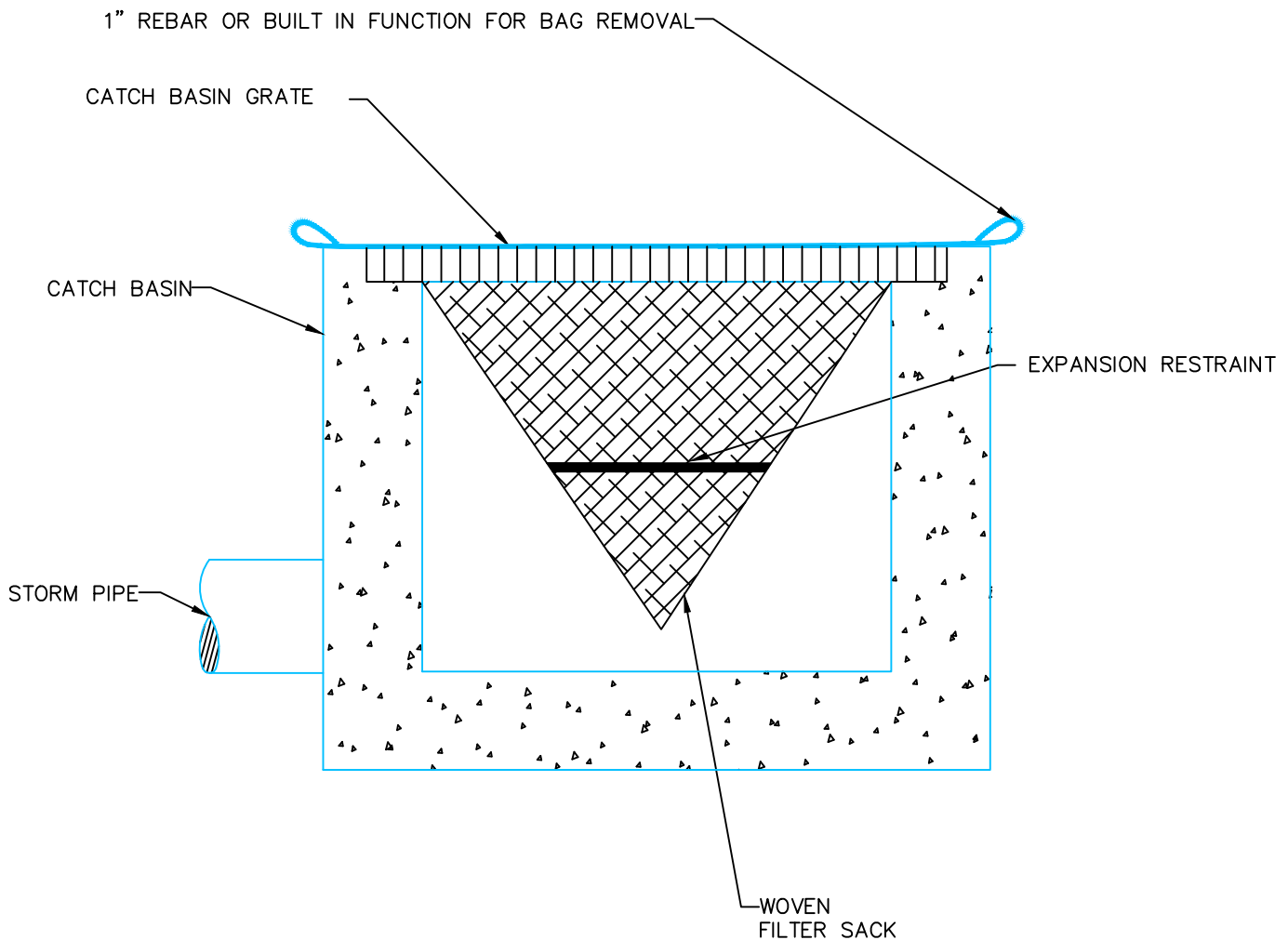

CATCH BASIN INSERT (WITCHES HAT)

NOTE:

1. RECESSED CURB INLET CATCH BASINS MUST BE BLOCKED WHEN USING FILTER FABRIC INLET SACKS. SIZE OF FILTER FABRIC INLET SACKS TO BE DETERMINED BY MANUFACTURER.

FOR FURTHER INFORMATION ON DESIGN CRITERIA SEE CHAPTER 4 OF CLEAN WATER SERVICES EROSION PREVENTION AND SEDIMENT CONTROL PLANNING AND DESIGN MANUAL.

**CATCH BASIN PROTECTION (WITCHES HAT)**

DETAIL: 145 LCPW E&SC - CATCH BASIN PROTECTION

REVISED:  
APRIL 2019



Lincoln City

MATS/BLANKETS SHOULD BE INSTALLED VERTICALLY DOWNSLOPE.

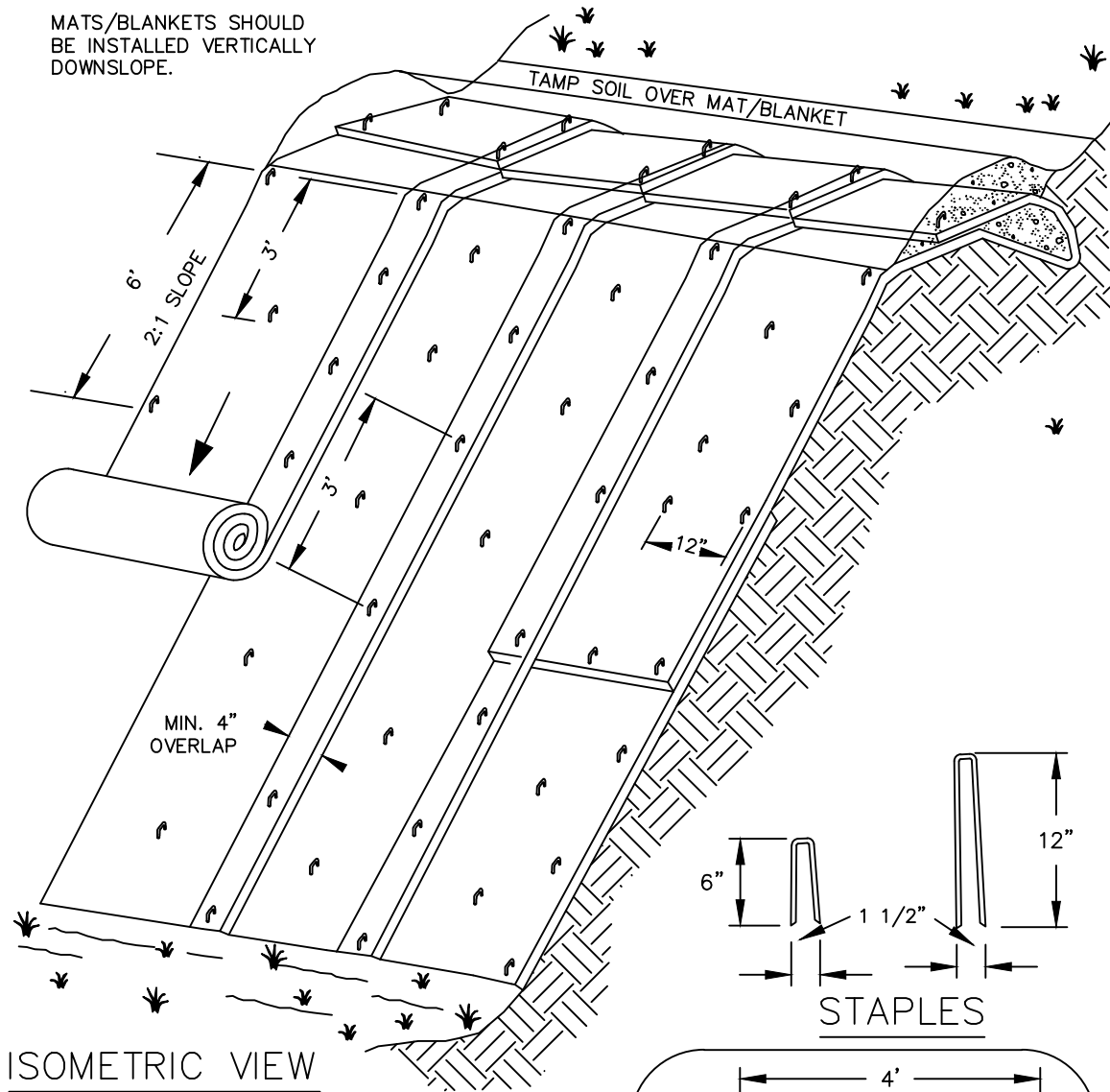

ISOMETRIC VIEW

TYPICAL SLOPE SOIL STABILIZATION

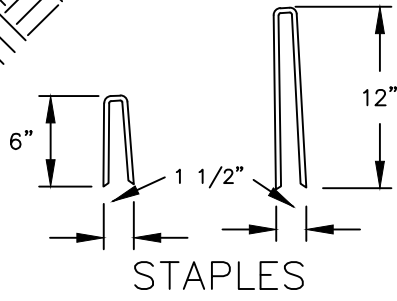

STAPLES

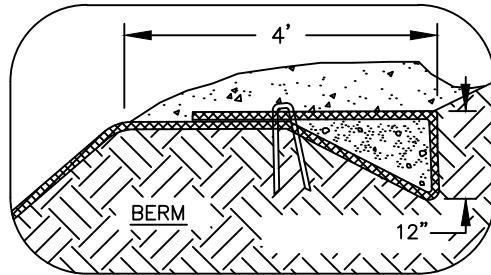

NOT TO SCALE

NOTES:

1. SLOPE SURFACE SHALL BE FREE OF ROCKS, CLODS, STICKS AND GRASS. MATS/BLANKETS SHALL HAVE GOOD SOIL CONTACT.
2. SEE DETAIL: 155, 160 LCPW E&SC FOR SLOPE PREPARATION TO PREVENT RILLING UNDER MATS
3. APPLY PERMANENT SEEDING BEFORE PLACING BLANKETS.
4. LAY BLANKETS LOOSELY AND STAKE OR STAPLE TO MAINTAIN DIRECT CONTACT WITH THE SOIL. DO NOT STRETCH.
5. STAKING OR STAPLING LAYOUT PER MANUFACTURERS SPECIFICATIONS.

**MATTING SLOPE INSTALLATION**

DETAIL: 150 LCPW E&SC - MATTING SLOPE INSTALLATION

REVISED:  
APRIL 2019



FOR FURTHER INFORMATION  
ON DESIGN CRITERIA SEE  
CHAPTER 4 OF CLEAN WATER  
SERVICES EROSION PREVENTION  
AND SEDIMENT CONTROL  
PLANNING AND DESIGN MANUAL.

## STAIR STEPPING CUT SLOPES

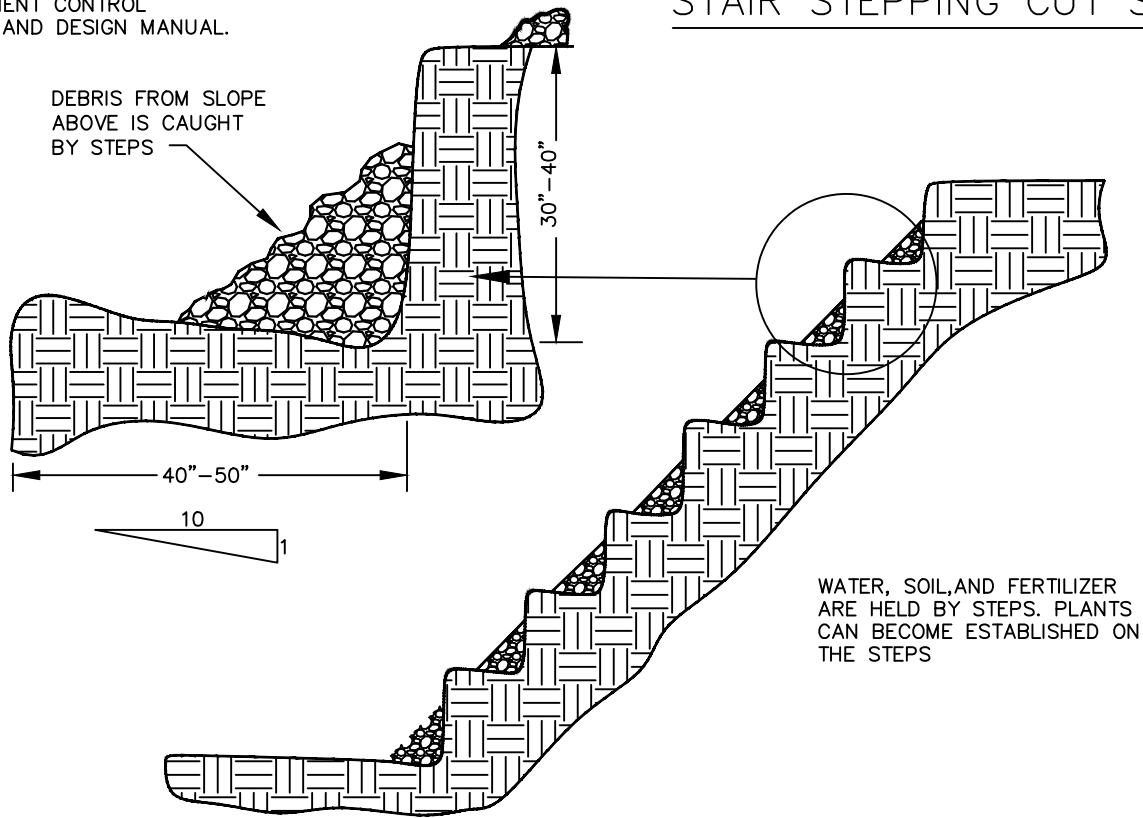

## GROOVING SLOPES

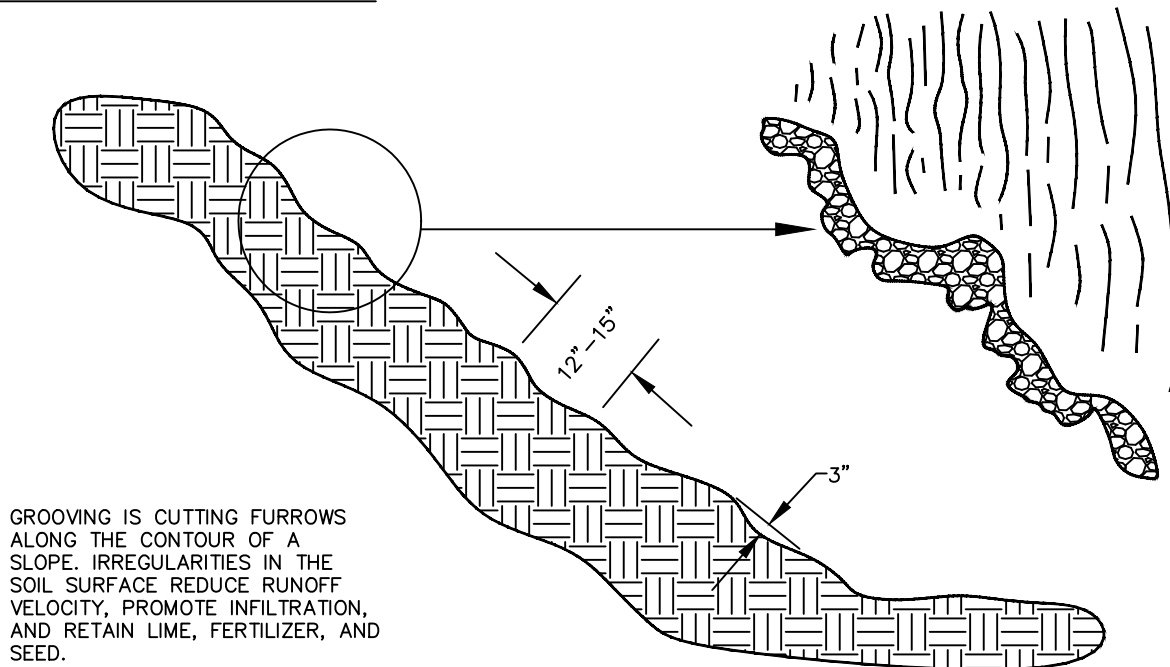

## SURFACE ROUGHING STAIR STEPPING/GROOVING SLOPES

DETAIL: 155 LCPW E&SC - SURFACE ROUGHING II

REVISED:  
APRIL 2019

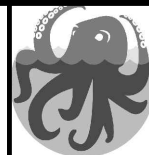

Lincoln  
City

FOR FURTHER INFORMATION  
ON DESIGN CRITERIA SEE  
CHAPTER 4 OF CLEAN WATER  
SERVICES EROSION PREVENTION  
AND SEDIMENT CONTROL  
PLANNING AND DESIGN MANUAL.

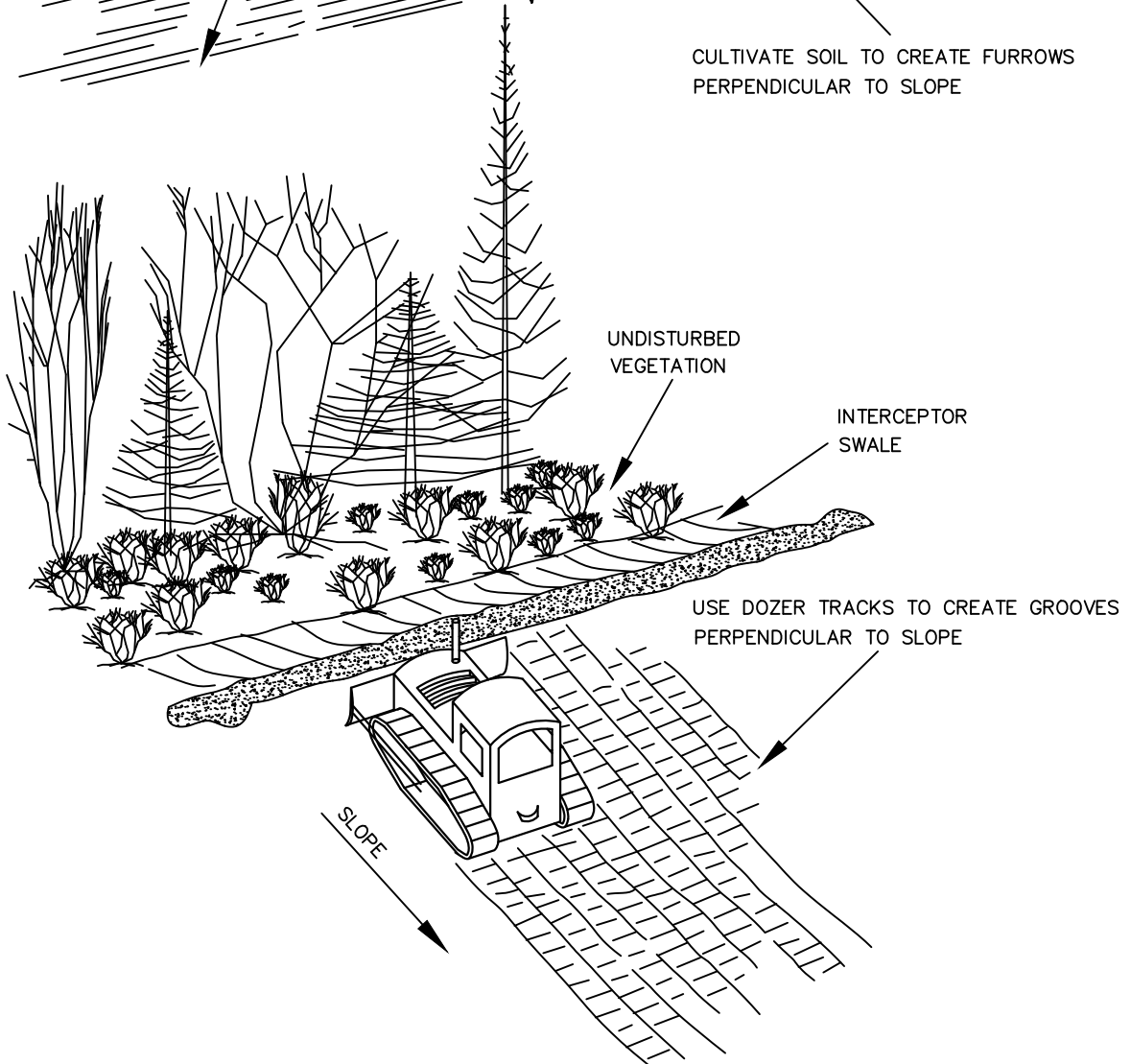
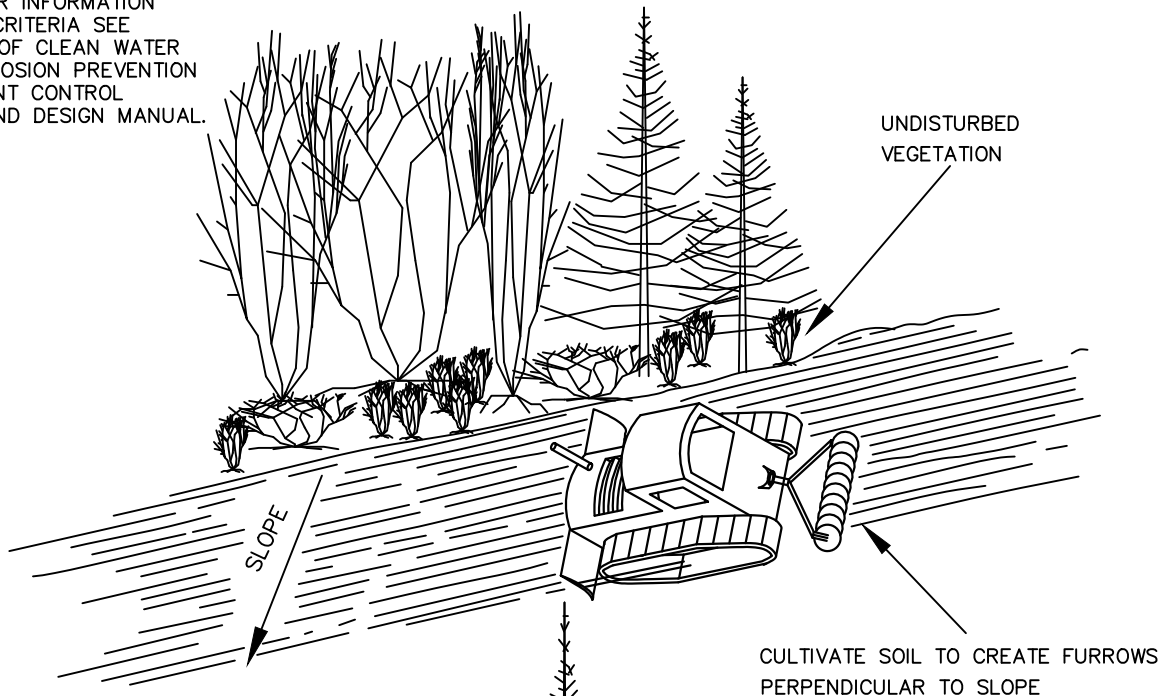

## SURFACE ROUGHING - CAT TRACK

DETAIL: 160 LCPW E&SC - Surface  
Roughing Cat Track

REVISED:  
APRIL 2019



Lincoln  
City

FOR FURTHER INFORMATION  
ON DESIGN CRITERIA SEE  
CHAPTER 4 OF CLEAN WATER  
SERVICES EROSION PREVENTION  
AND SEDIMENT CONTROL  
PLANNING AND DESIGN MANUAL.

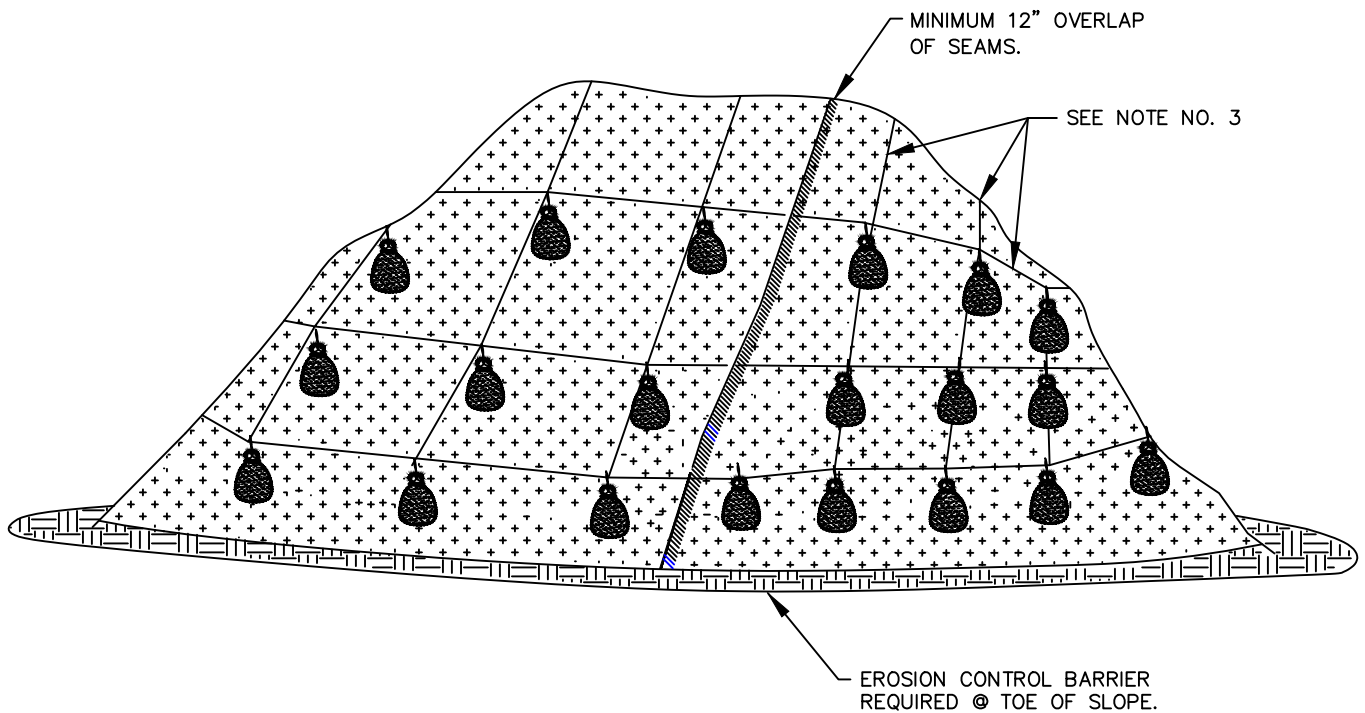

## PLASTIC SHEETING

### NOTES:

1. MINIMUM 12" OVERLAP OF ALL SEAMS REQUIRED.
2. BARRIER REQUIRED @ TOE OF STOCK PILE.
3. COVERING MAINTAINED TIGHTLY IN PLACE BY USING SANDBAGS OR APPROVED EQUAL ON ROPES WITH A MAXIMUM 10' GRID SPACING IN ALL DIRECTIONS.
4. PLASTIC TO EXTEND MINIMUM 1' BEYOND TOE OF SLOPE
5. USE OF JUTE, STRAW, COIR, EXCELSIOR MAT OR SIMILAR ALTERNATIVE IS ENCOURAGED.

## FILL PILE COVER - PLASTIC SHEETING

DETAIL: 165 LCPW E&SC - PLASTIC SHEETING

REVISED:  
APRIL 2019

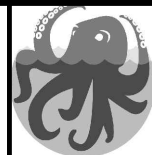

Lincoln  
City

FOR FURTHER INFORMATION  
ON DESIGN CRITERIA SEE  
CHAPTER 4 OF CLEAN WATER  
SERVICES EROSION PREVENTION  
AND SEDIMENT CONTROL  
PLANNING AND DESIGN MANUAL.

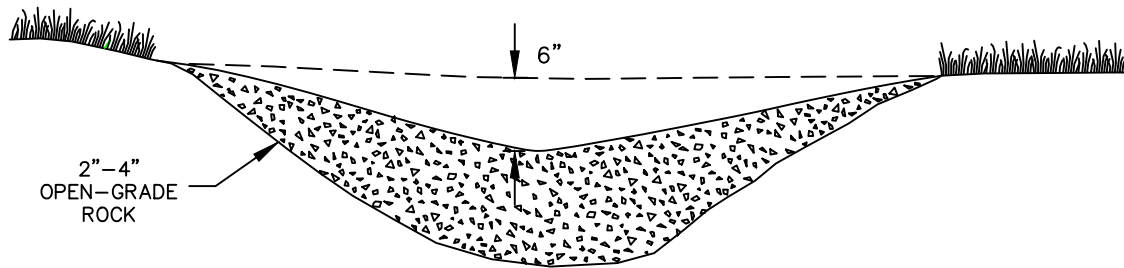

ROCK CHECK DAM

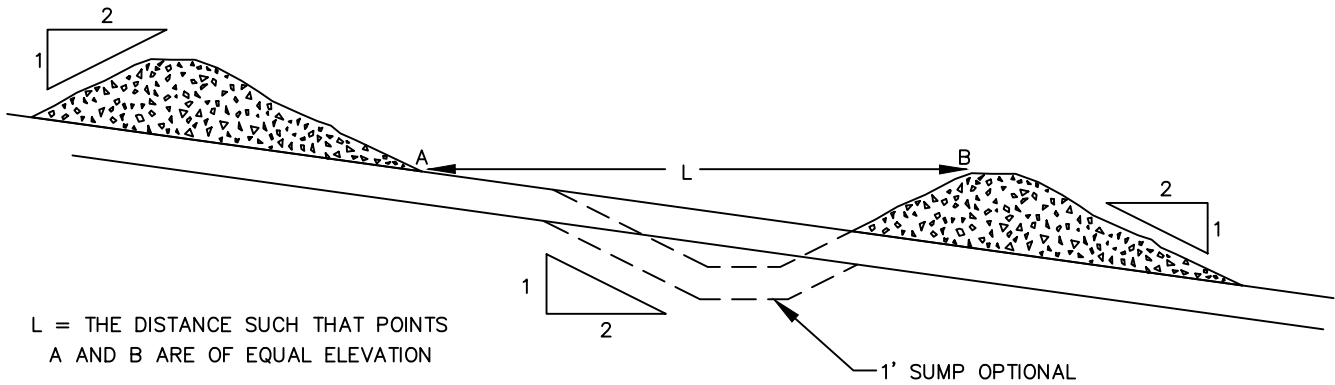

L = THE DISTANCE SUCH THAT POINTS  
A AND B ARE OF EQUAL ELEVATION

SPACING BETWEEN CHECK DAMS

CHECK DAM

DETAIL: 170 LCPW E&SC - CHECK DAM

REVISED:  
APRIL 2019



Lincoln  
City

FOR FURTHER INFORMATION  
ON DESIGN CRITERIA SEE  
CHAPTER 4 OF CLEAN WATER  
SERVICES EROSION PREVENTION  
AND SEDIMENT CONTROL  
PLANNING AND DESIGN MANUAL.

## SPACING FOR CHECK DAMS

DITCH GRADE			
	6 INCH	12 INCH	18 INCH
6%	NOT ALLOWED	16 FT O.C.	26 FT O.C.
5%	NOT ALLOWED	20 FT	30 FT
4%	NOT ALLOWED	26 FT	40 FT
3%	15 FT	33 FT	50 FT
2%	25 FT	50 FT	80 FT

## BARRIER SPACING FOR GENERAL APPLICATION

**INSTALL PARALLEL ALONG CONTOURS AS FOLLOWS**

% SLOPE	SLOPE	MAXIMUM SPACING ON SLOPE
10% OR FLATTER	10:1 OR FLATTER	300 FT
>10% OR <15%	>10:1 OR <7.5:1	150 FT
>15% OR <20%	>7.5:1 OR <5:1	100 FT
>20% OR <30%	>5:1 OR <3.5:1	50 FT
>30% OR <50%	>3.5:1 OR <2:1	25 FT

**NOTES:**

1. FOR MORE INFORMATION REGARDING THESE TABLES SEE CHAPTER 4 TABLES 4-3 AND 4-7 OF CLEAN WATER SERVICES EROSION PREVENTION AND SEDIMENT CONTROL DESIGN MANUAL.

### BARRIER SPACING TABLE

DETAIL: 175 LCPW E&SC - BARRIER  
SPACING TABLE

REVISED:  
APRIL 2019



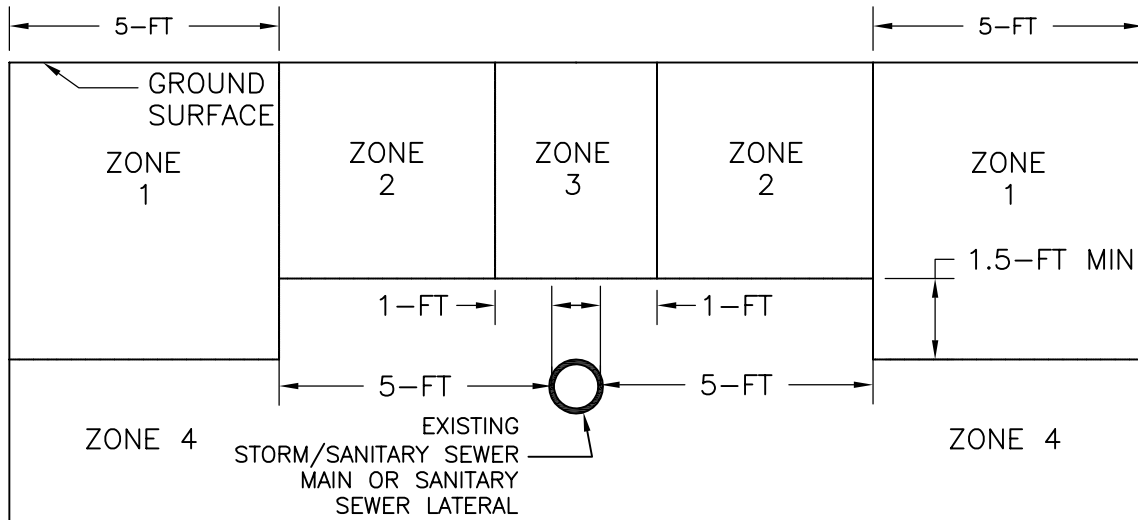

ZONE 1: ONLY CROSSING RESTRICTIONS APPLY  
 ZONE 2: CASE-BY-CASE DETERMINATION

ZONE 3: PARALLEL WATER LINE PROHIBITED  
 ZONE 4: PARALLEL WATER LINE PROHIBITED

**NOTES:**

1. IN SITUATIONS INVOLVING A WATER LINE PARALLEL TO A STORM OR SANITARY SEWER MAIN (STORM/SANITARY) OR SEWER LATERAL, THE THE SEPARATION BETWEEN THE TWO SHALL BE AS INDICATED IN THE ABOVE FIGURE.
2. IN SITUATIONS WHERE A WATER LINE & A STORM/SANITARY MAIN OR SEWER LATERAL CROSS, THE SEPARATION SHALL BE AS FOLLOWS:
  - (A) WHEREVER POSSIBLE, THE BOTTOM OF THE WATER LINE SHALL BE 1.5-FEET OR MORE ABOVE THE TOP OF THE STORM/SANITARY LINE & ONE FULL LENGTH OF THE WATER LINE SHALL BE CENTERED AT THE CROSSING.
  - (B) WHERE THE WATER LINE CROSSES OVER THE STORM/SANITARY LINE BUT W/ A CLEARANCE OF LESS THAN 1.5-FEET, THE STORM/SANITARY LINE SHALL BE EXPOSED TO THE JOINTS ON BOTH SIDES OF THE CROSSING FOR EXAMINATION OF THE PIPE BY A LINCOLN CITY PUBLIC WORKS DEPARTMENT (LCPWD) REPRESENTATIVE. IF THE STORM/SANITARY PIPE IS IN GOOD CONDITION & THERE IS NO EVIDENCE OF LEAKAGE, THE 1.5-FEET SEPARATION MAY BE REDUCED. HOWEVER, IN THIS SITUATION, THE APPLICANT MUST CENTER ONE LENGTH OF THE WATER LINE AT THE CROSSING & MUST PREPARE A WRITTEN REPORT OF THE FINDINGS & INDICATE THE REASONS FOR REDUCING THE SEPARATION FOR SUBMISSION TO LCPW WATER DEPT. IF THE CONDITIONS ARE NOT FAVORABLE OR IF THERE IS EVIDENCE OF LEAKAGE FROM THE STORM/SANITARY LINE, THE STORM/SANITARY LINE SHALL BE REPLACED W/ A FULL LENGTH OF PIPE CENTERED AT THE CROSSING POINT, OR THE STORM/SANITARY LINE SHALL BE ENCASED IN A REINFORCED CONCRETE JACKET FOR A DISTANCE OF 10-FEET ON BOTH SIDES OF THE CROSSING.
  - (C) WHERE THE WATER LINE CROSSES UNDER THE STORM/SANITARY LINE, THE APPLICANT SHALL EXPOSE THE STORM/SANITARY LINE FOR EXAMINATION BY A LCPWD REPRESENTATIVE AS INDICATED IN NOTE (2)(B) OF THIS STANDARD. IF CONDITIONS ARE FAVORABLE & THERE IS NO EVIDENCE OF LEAKAGE FROM THE STORM/SANITARY LINE, THE STORM/SANITARY LINE MAY BE LEFT IN PLACE, BUT SPECIAL PRECAUTIONS MUST BE TAKEN TO ASSURE THAT THE BACKFILL MATERIAL OVER THE WATER LINE IN THE VICINITY OF THE CROSSING IS THOROUGHLY TAMPED IN ORDER TO PREVENT SETTLEMENT WHICH COULD RESULT IN LEAKAGE OF THE STORM/SANITARY. IN THIS SITUATION, THE APPLICANT MUST CENTER ONE LENGTH OF THE WATER LINE AT THE CROSSING & MUST PREPARE A WRITTEN REPORT FOR SUBMISSION TO LC PWD RECORDING THE MANNER IN WHICH THE STORM/SANITARY LINE WAS SUPPORTED AT THE CROSSING & THE MATERIAL & METHODS USED IN BACKFILLING & TAMPING TO PREVENT SETTLEMENT OF THE STORM/SANITARY LINE. IF THE APPLICANT DETERMINES THAT CONDITIONS ARE NOT FAVORABLE OR FINDS EVIDENCE OF LEAKAGE FROM THE STORM/SANITARY LINE, THE PROVISIONS OF NOTE (2)(B) OF THIS STANDARD APPLY.
  - (D) WHEN A WATER MAIN IS INSTALLED UNDER A STREAM OR OTHER WATERCOURSE, A MINIMUM COVER OF 30 INCHES SHALL BE PROVIDED OVER THE PIPE. WHERE THE WATERCOURSE IS MORE THAN 15-FEET WIDE, THE PIPE SHALL BE OF SPECIAL CONSTRUCTION W/ FLEXIBLE WATERTIGHT JOINTS, VALVES SHALL BE PROVIDED ON BOTH SIDES OF THE CROSSING SO THAT THE SECTION CAN BE ISOLATED FOR TESTING OR REPAIR, & TEST COCKS SHALL BE PROVIDED AT THE VALVES.
  - (E) IN SITUATIONS NOT COVERED BY THIS STANDARD, THE APPLICANT SHALL GAIN APPROVAL FROM LCPWD PRIOR TO CONSTRUCTION.

**LCPW PIPE CLEARANCES**

DETAIL: 500 LCPW WATER-PIPE CLEARANCES

REVISED:  
 APRIL 2019



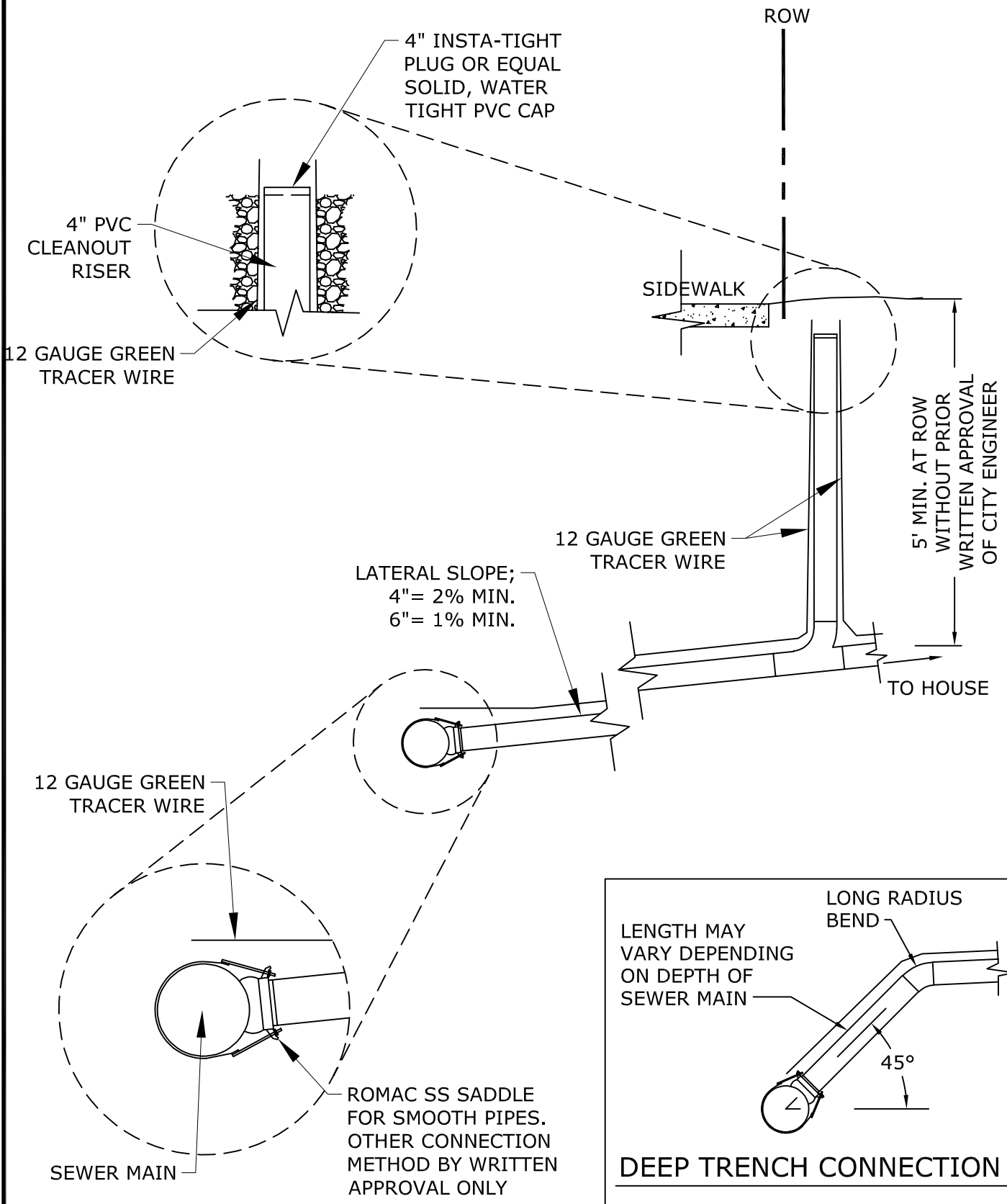

FACTORY TEES SHALL BE USED FOR LATERAL INSTALLATION ON NEW MAINS

## STANDARD SEWER SERVICE LATERAL

200-LCPW Sewer-Standard Sanitary Sewer Service Lateral

REVISED:  
DEC - 2019



### END OF LINE FLUSH STATION - PLAN

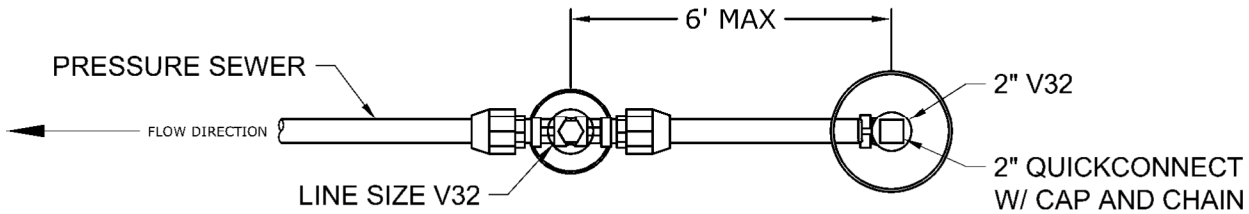

### END OF LINE FLUSH STATION - SECTION

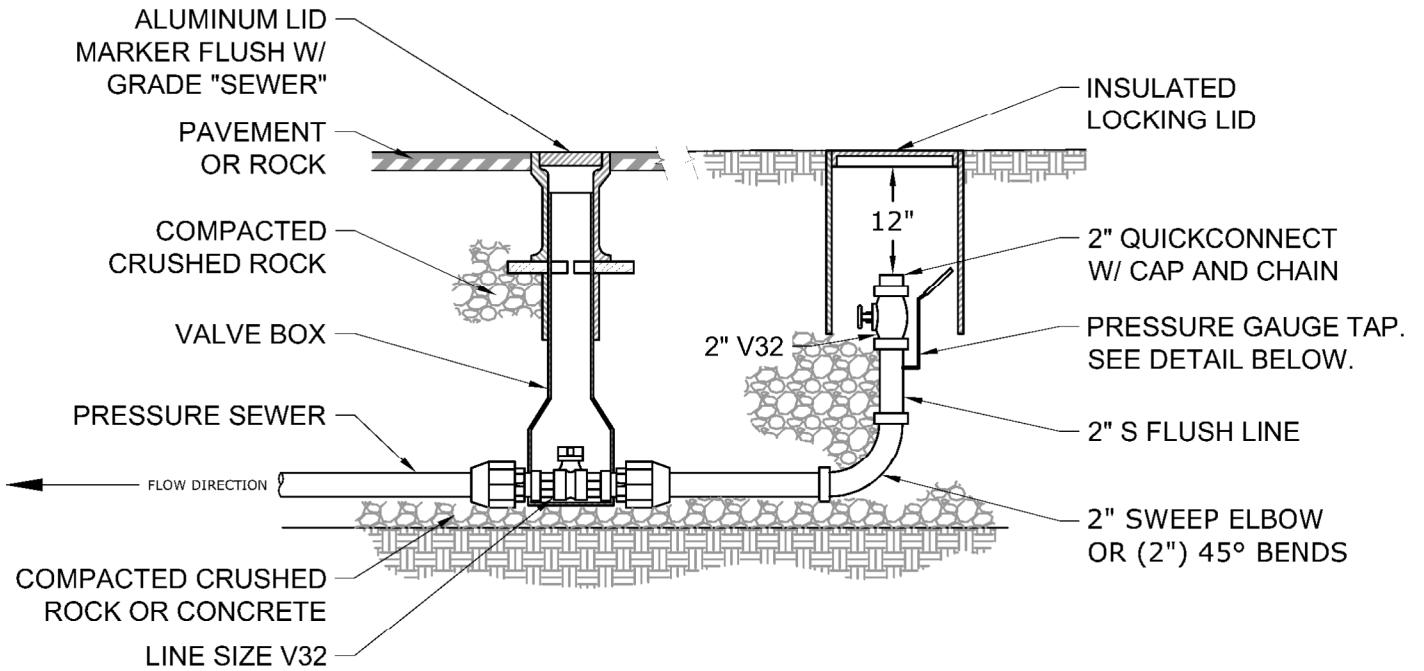

### PRESSURE GAUGE TAP DETAIL

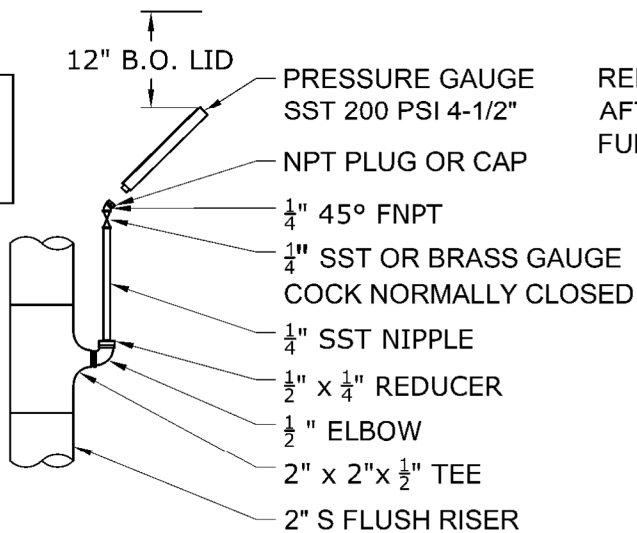

REMOVE GAUGES AFTER TESTING. FURNISH TO OWNER

## END OF LINE FLUSH STATION

Detail: 210-LCPW Sewer-End of Line Flush Station

REVISED:  
MAY - 2020



**END OF LINE FLUSH STATION - PLAN**

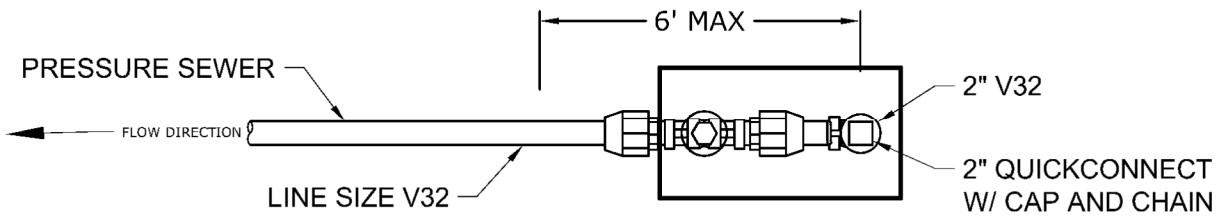

**END OF LINE FLUSH STATION - SECTION**

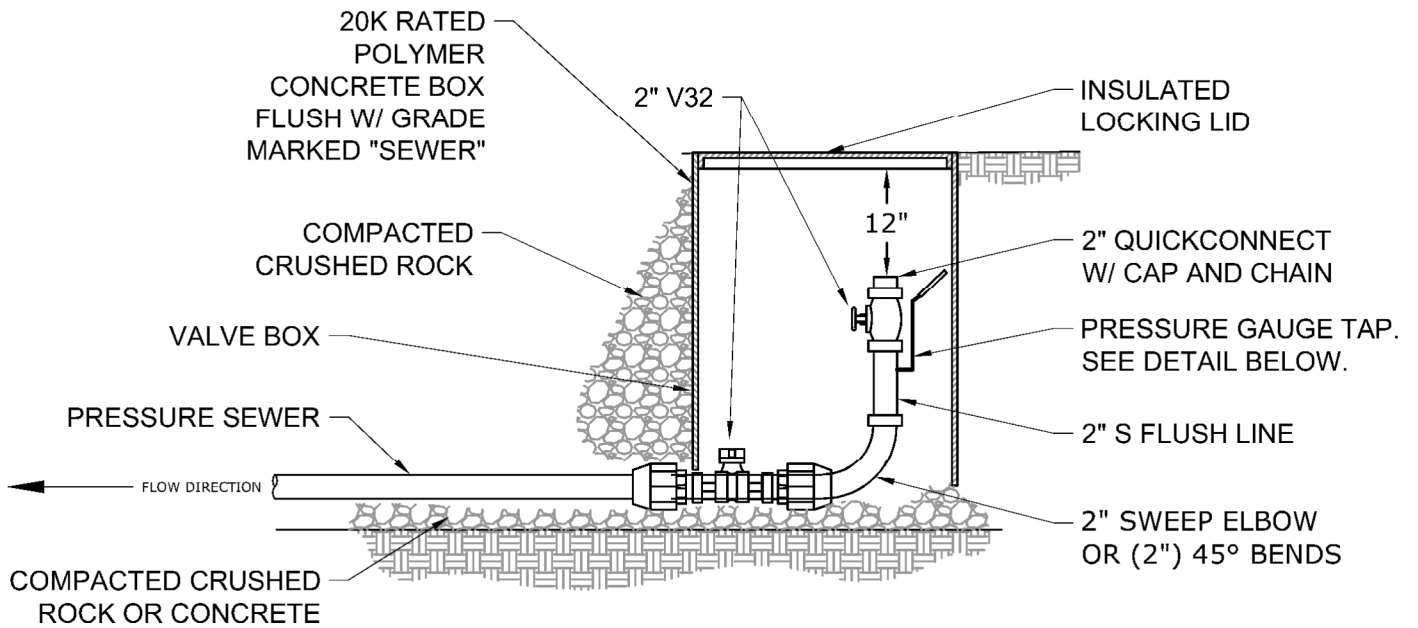

**PRESSURE GAUGE TAP DETAIL**

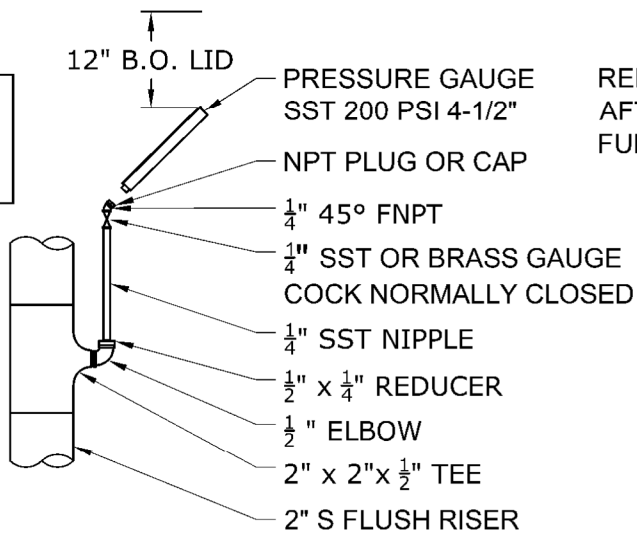

REMOVE GAUGES AFTER TESTING. FURNISH TO OWNER

**ALTERNATIVE END OF LINE FLUSH STATION**

Detail: 211-LCPW Sewer-End of Line Flush Station, Alt.

REVISED:  
JULY - 2020



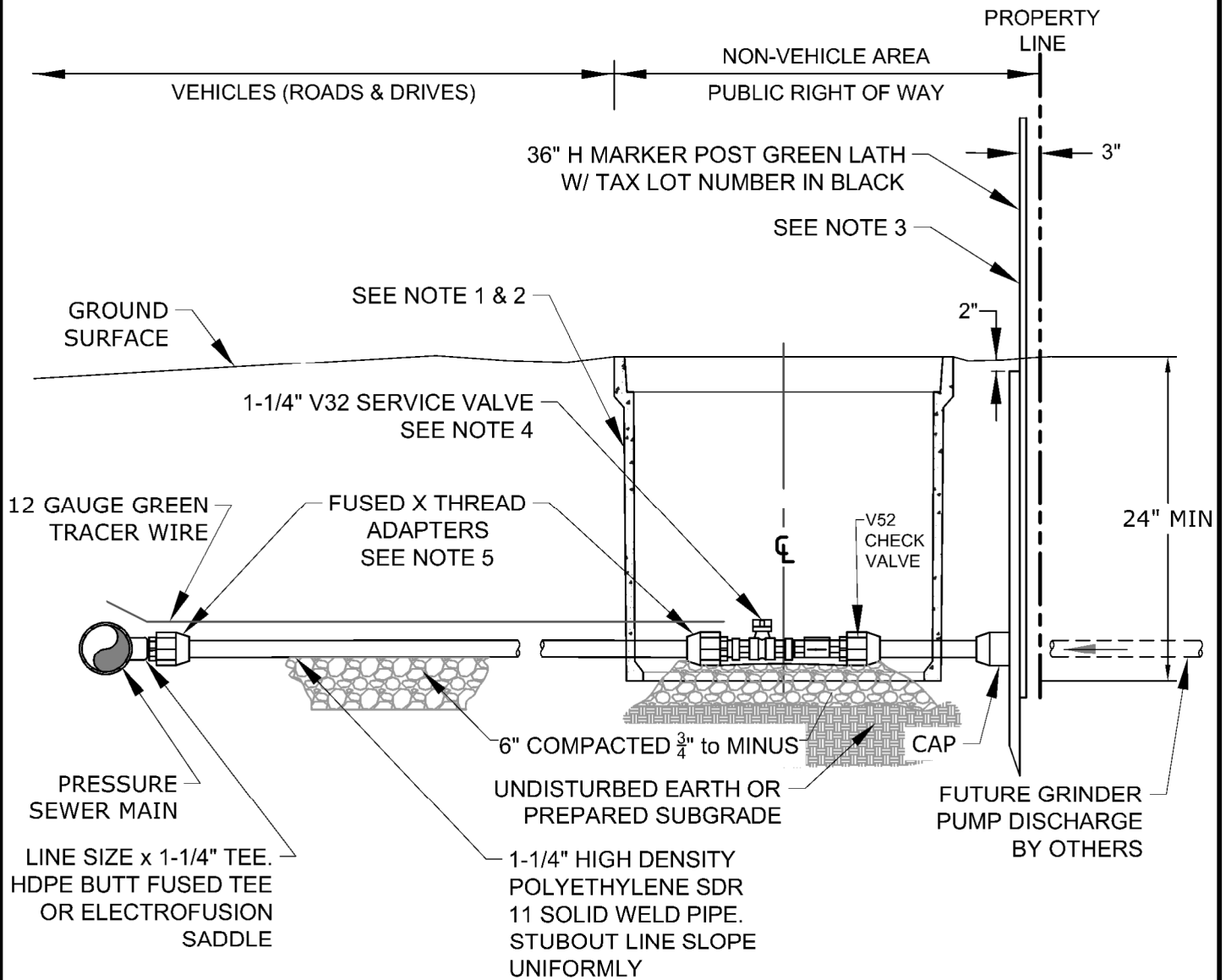

**NOTES:**

1. PLACE SERVICE VAULT AT THE BACK OF SIDEWALK & AWAY FROM VEHICULAR TRAFFIC IF POSSIBLE.
2. HAND HOLE VAULT AND LID SHALL BE 20K LOAD RATED ARMORCAST A6001946HDAPCX24 13"W X 24"L X 24"D 20K.
3. IF NOT IMMEDIATELY CONNECTING TO GRINDER PUMP THEN PLACE 2x4 PT STAKE PAINT TOP 6" BRIGHT GREEN. IF IN ASPHALT OR CONC., PLACE 2" PK NAIL FLUSH W/ GRADE. PAINT PK NAIL BRIGHT GREEN INSTEAD OF STAKE.
4. VALVE ASSEMBLY MAY BE [1] ASSEMBLED ON-SITE ACCORDING TO MATERIAL REQUIREMENTS AND MANUFACTURER ASSEMBLY SPECIFICATIONS, [2] E-ONE STAINLESS STEEL UNILATERAL ASSEMBLY OR [3] EQUIVALENT  
IF ASSEMBLING ONSITE ALL VALVES SHALL BE DOMESTIC AND EITHER BRASS, STAINLESS, OR THREADED PVC. SERVICE VALVE SHALL BE TRUE UNION TYPE. ALL PRESSURE RATINGS SHALL BE 200 PSI OR BETTER.
5. ALL FITTINGS SHALL BE BRASS OR MOLDED HDPE RATED FOR 200 PSI OR BETTER.

**STANDARD LOW PRESSURE SEWER SERVICE**

Detail: 220 LCPW Sewer-Std Lo Press Swr Svc

REVISED  
JULY - 2020



Lincoln City

# SIDEWALK PLAN VIEW

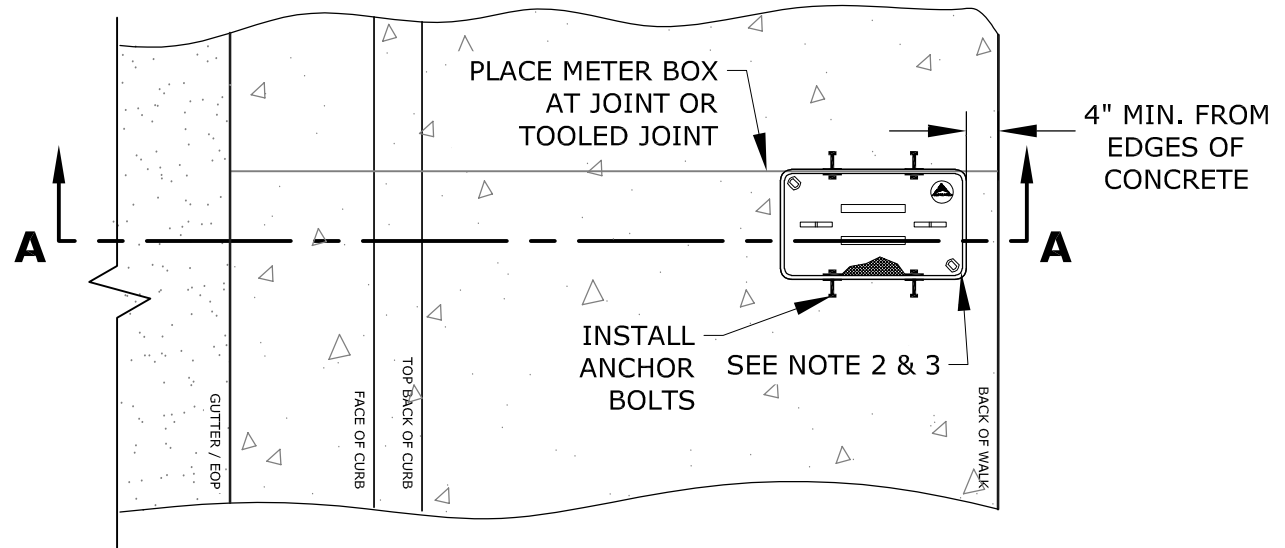

# SIDEWALK SECTION A-A

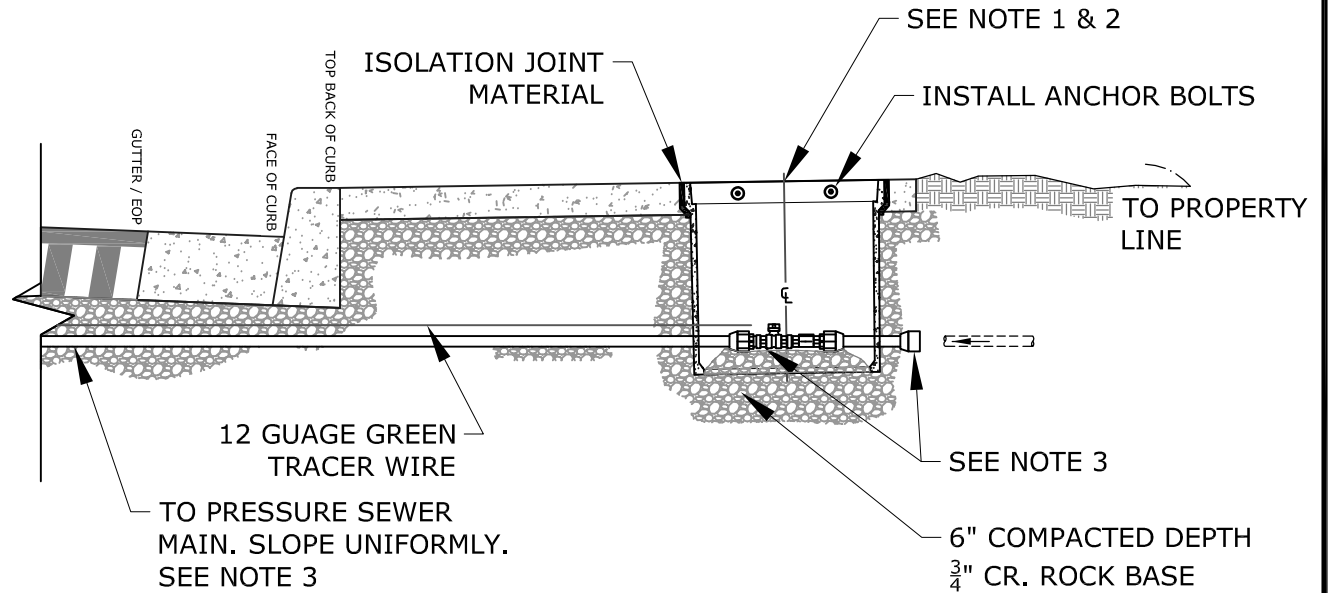

**NOTES:**

1. PLACE SERVICE VAULT AT THE BACK OF SIDEWALK & AWAY FROM VEHICULAR TRAFFIC IF POSSIBLE.
2. HAND HOLE VAULT & LID SHALL BE 20K LOAD RATED ARMORCAST A6001946HDAPCX24 13"W X 24"L X 24"D.
3. SEE DETAIL: 220 LCPW Sewer-Std Lo Press Swr Svc

## Std Lo Pressure Sewer Service-On Sidewalk

Detail: 225 LCPW Sewer-Std Lo Press Swr Svc-On Swk

REVISED:  
MAY - 2020



LCPW STANDARD BIOFILTRATION SWALE

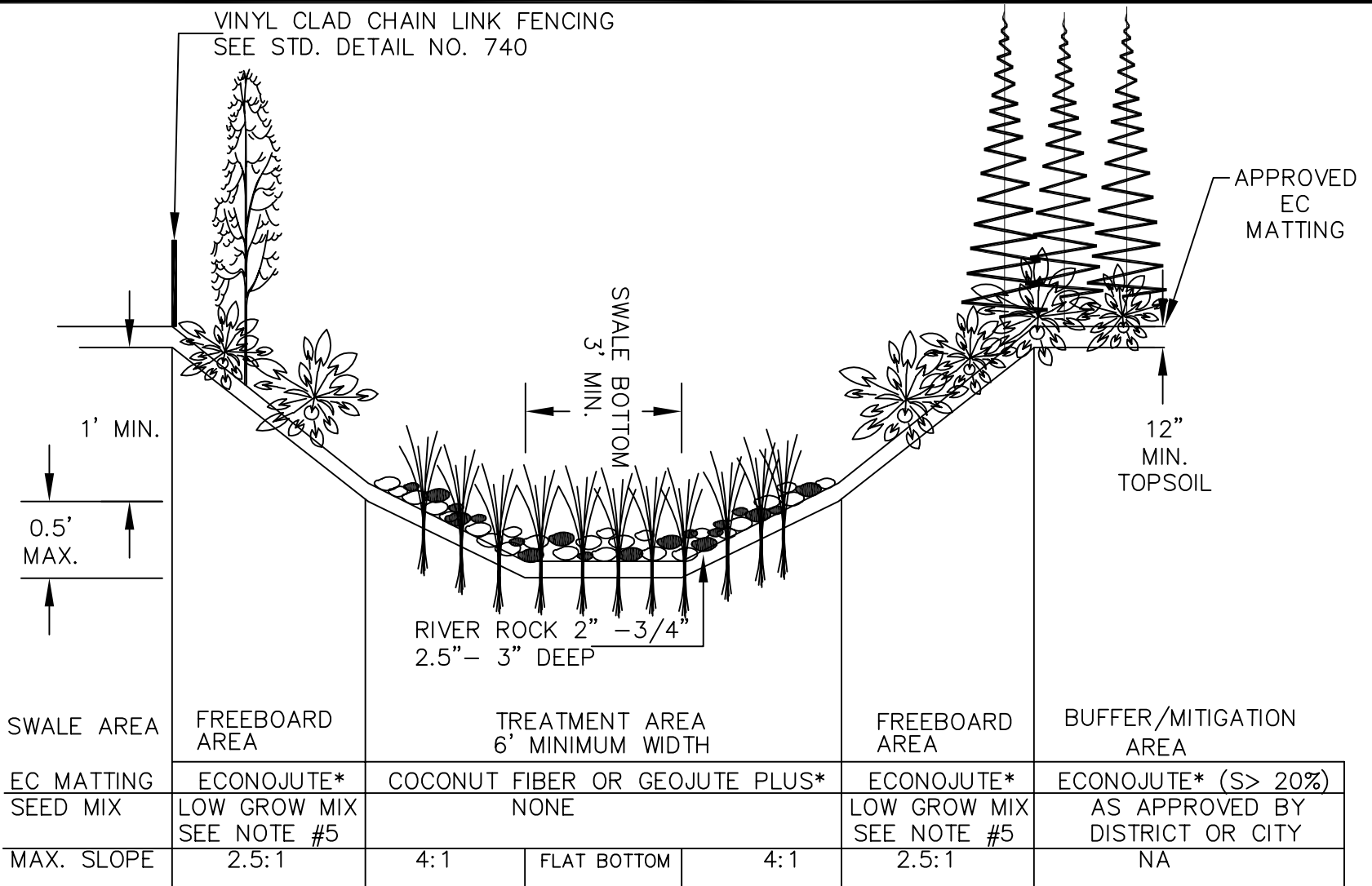

SWALE AREA	FREEBOARD AREA	TREATMENT AREA 6' MINIMUM WIDTH		FREEBOARD AREA	BUFFER/MITIGATION AREA
EC MATTING	ECONOJUTE*	COCONUT FIBER OR GEOJUTE PLUS*		ECONOJUTE*	ECONOJUTE* (S> 20%)
SEED MIX	LOW GROW MIX SEE NOTE #5	NONE		LOW GROW MIX SEE NOTE #5	AS APPROVED BY DISTRICT OR CITY
MAX. SLOPE	2.5:1	4:1	FLAT BOTTOM	4:1	2.5:1
					NA

\* OR AS APPROVED

NOTES:

- REFER TO APPENDIX A, CWS DESIGN & CONSTRUCTION STANDARDS, FOR LANDSCAPING REQUIREMENTS INCLUDING TREE PLACEMENT, TOPSOIL AND PLANTING SPECIFICATIONS.
- 0.5% ≤ LONGITUDINAL SLOPE ≤ 2%. PROVIDE IRRIGATION AS APPROVED BY CWS.
- JUTE MATTING- GEOJUTE PLUS IN TREATMENT AREA, ECONOJUTE FOR ALL OTHER AREAS, OR SIMILIAR FABRICS. COCONUT FIBER IS ALSO ACCEPTABLE.
- 12-INCHES OF TOPSOIL SHALL BE PLACED THROUGHOUT THE WATER QUALITY TRACT.
- FREEBOARD AREA SEED MIX, DWARF TALL FESCUE 40%, DWARF PERENIAL RYE 30%, CREEPING RED FESCUE 25%, COLONIAL BENT GRASS 5%. APPLY AT A RATE OF 120# / ACRE.



**NOTES:**

1. SITE SOILS MUST BE ADEQUATELY PERMEABLE TO INFILTRATE RUNOFF INTO GROUNDWATER. A MINIMUM INFILTRATION RATE OF 2 INCHES PER HOUR IS REQUIRED AT THE FACILITY BASE. REFER TO THE CITY OF LINCOLN CITY'S STORMWATER MANAGEMENT ALTERNATIVES FOR SINGLE FAMILY RESIDENCES FOR INFORMATION ON HOW TO TEST THE INFILTRATION RATE OF THE SOIL.
2. PROPERTY MUST BE LOCATED OUTSIDE OF THE SEASONAL HIGH GROUND WATER ZONE AS DETERMINED BY LC PWD GIS MAPS.
3. DRYWELLS ARE NOT ALLOWED IN THE PUBLIC RIGHT-OF-WAY.
4. DRYWELLS MUST BE AT LEAST 100 FEET FROM THE TOP OF ANY SLOPE 20% OR GREATER, UNLESS A GEOTECHNICAL REPORT IS SUBMITTED THAT VERIFIES THAT THE DRYWELL PLACED WITHIN 100 FEET FROM THE TOP OF THE SLOPE WILL NOT COMPROMISE THE STABILITY OF THE SLOPE.
5. DRYWELLS MUST BE AT LEAST 5 FEET FROM PROPERTY LINES AND 10 FEET FROM BUILDING FOUNDATIONS. THE TOP OF THE DRYWELL SHALL BE LOCATED DOWNGRAIDENT FROM THE FOUNDATIONS AND AT A LOWER ELEVATION THAN LOCAL BASEMENTS.
5. DRYWELLS MUST BE AT LEAST 500 FEET FROM ANY DRINKING WATER WELLS AND SHOULD BE DOWNGRAIDENT FROM SEPTIC DRAIN FIELDS.
6. DRYWELLS MAY NOT BE CONSTRUCTED BENEATH AN IMPERVIOUS SURFACE OR A PERVIOUS SURFACE SUBJECT TO VEHICLE TRAFFIC.

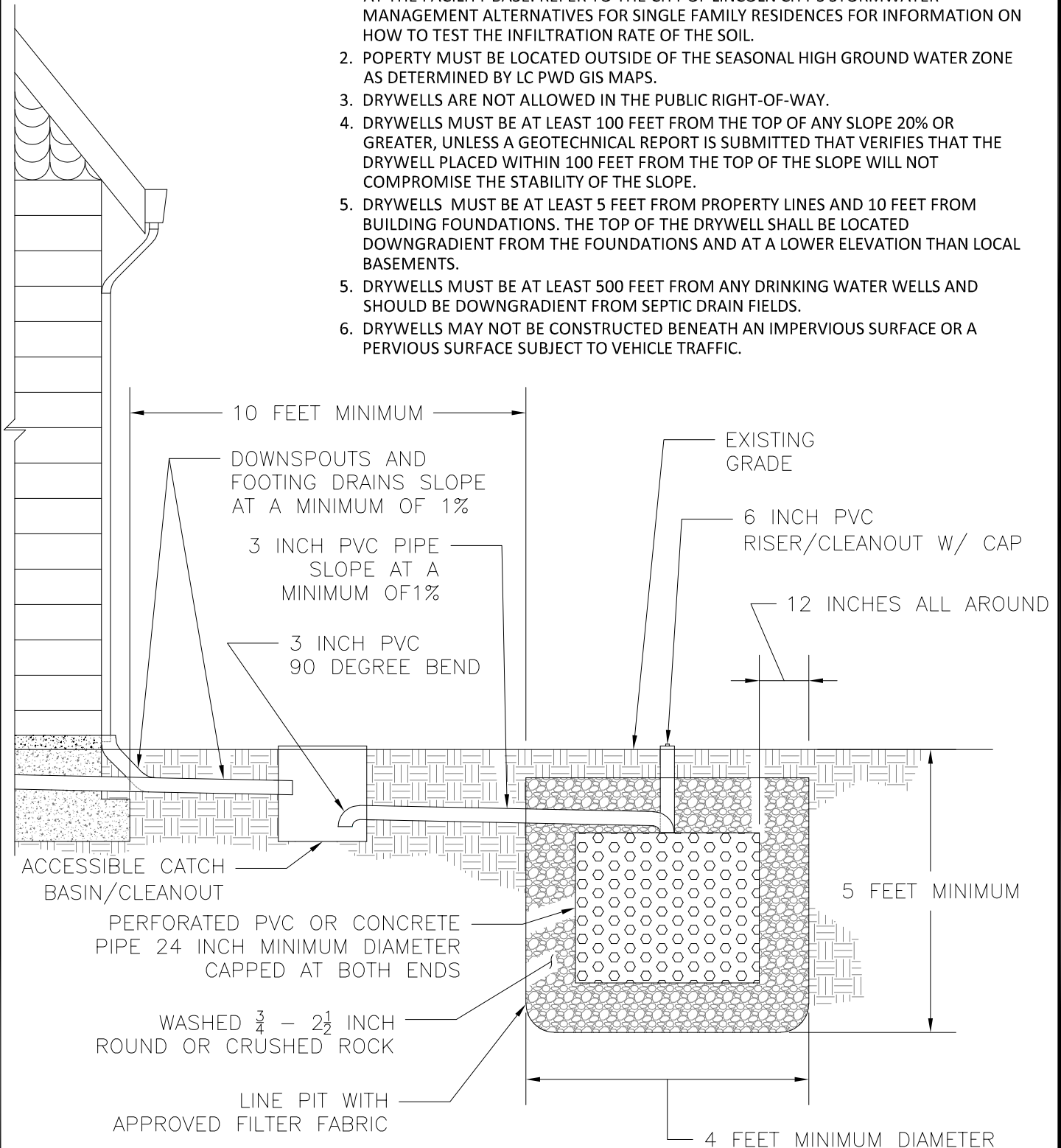

**LCPW STANDARD DRYWELL**

DETAIL: 320 LCPW OnSiteStorm-Drywell

REVISED:  
APRIL 2019



Lincoln City

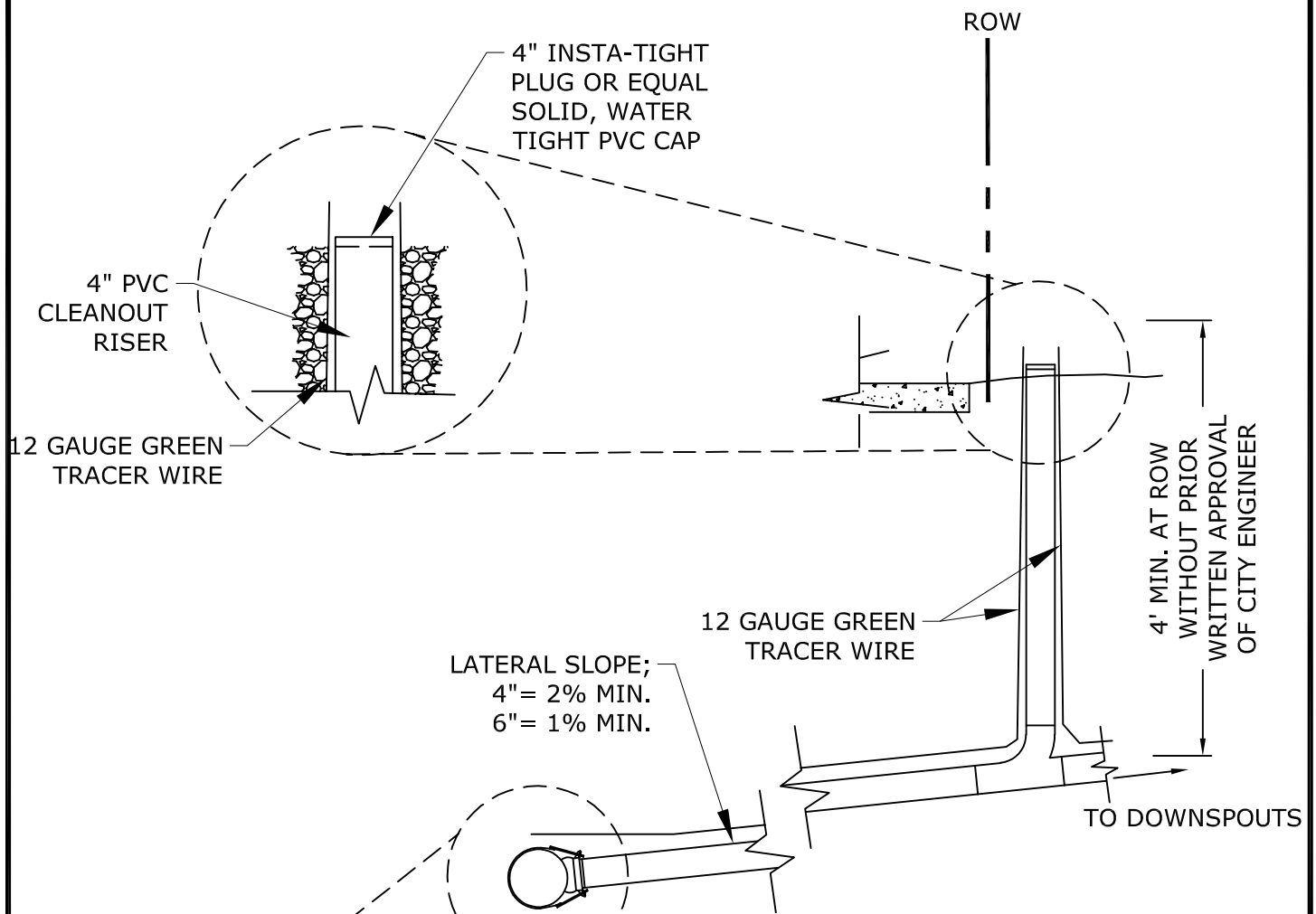

12 GAUGE GREEN TRACER WIRE

4" PVC CLEANOUT RISER

4" INSTA-TIGHT PLUG OR EQUAL SOLID, WATER TIGHT PVC CAP

ROW

12 GAUGE GREEN TRACER WIRE

4' MIN. AT ROW WITHOUT PRIOR WRITTEN APPROVAL OF CITY ENGINEER

LATERAL SLOPE;  
4" = 2% MIN.  
6" = 1% MIN.

TO DOWNSPOUTS

12 GAUGE GREEN TRACER WIRE

STORM SEWER MAIN

ROMAC SS SADDLE FOR SMOOTH PIPES. INSERT-A OR CORRUGATED SADDLE FOR CORRUGATED PIPE.

- 1) Connect to storm system only after consultation & approval from LCPW.
- 2) All work must adhere to LCPW construction standards.
- 3) Work must be inspected by LCPW prior to trench backfill.
- 4) Placement of backflow devices and/or connection of perforated pipes to the public system shall both be at owner's discretion.
- 5) Pipe-to-structure connections must be grouted inside & out of the pipe connection.

## STANDARD STORM SEWER CONNECTION

315-LCPW Storm-Standard Storm Service Lateral

REVISED:  
DEC - 2021



RIGHT OF WAY

PLACE METER BOX SO THAT  
BACK OF BOX APPROX. 1' INSIDE  
OF PUBLIC RIGHT-OF-WAY.

1" IPS BRASS  
FULL PORT MxM  
CORP STOP

SERVICE  
SADDLE

45°

1" IPS BRASS  
FMxCOMP W/  
SS INSERT

12 GAUGE BLUE  
TRACER WIRE

SEAMLESS 1"  
IPS BLUE POLY  
PIPE CL200 PSI

WATER  
MAIN

SENSUS  
RADIO READ  
iPEARL

SEE NOTE 4

SEE NOTE 3

6" COMPACTED  
DEPTH  $\frac{3}{4}$ " CR.  
ROCK BASE

**NOTES:**

1. METER VAULTS SHALL BE PLACED AT THE BACK OF SIDEWALK & AWAY FROM VEHICULAR TRAFFIC IF POSSIBLE.
2. METER VAULT & LID SHALL BE ARMORCAST A6000485 FOR 1" 12"X12"X20".
3. USE WEIGHT RATING FOR VAULT ACCORDING TO MAX WEIGHT VEHICLE TRAFFIC.
4. ALL FITTINGS SHALL BE BRASS W/ SS INSERTS.
5. CUSTOMER SERVICE VALVE SHALL BE GLOBE METER,  $\frac{3}{4}$ " IPS, STRAIGHT, FORD S6. 13-332 OR EQUIVALENT.
6. CONSULT WITH LCPW FOR DESIGN VARIANCES DUE TO LARGER SERVICES.

## STND Water Service ( $\frac{5}{8}$ " to 2") Off Sidewalk

DETAIL: 510 LCPW WATER-Standard Water Service  
Off Sidewalk

REVISED:  
MAY - 2020



Lincoln  
City

RIGHT OF WAY

PLACE METER BOX/VAULT SO THAT BACK OF BOX APPROX. 1' INSIDE OF PUBLIC RIGHT-OF-WAY OR RECORDED EASEMENT

2" NRS RESILIENT SEAT GV (FMxFM)

202 NS SS SERVICE SADDLE

2" COUPLER (MLxCMP) WITH SS INSERT

VC212 VALVE COVER AND VANCOUVER VALVE CAN

2" BRASS NIPPLE (IPS)

2" BLUE IPS POLY PIPE & 12-GAUGE BLUE TRACER WIRE

WATER MAIN

CONCRETE BLOCK

OMNI C2 - 13" to 15 1/4" length See Specs

ARMORCAST OR FIBERLYTE METER BOX (17"X30") LID TO BE 20K RATED WITH AMR/AMI KNOCKOUT

DOMESTIC BRASS METER SETTER & SIDE BYPASS PER LCPW STANDARDS

VARIABLE RISER HEIGHT AS REQUIRED FOR PIPE DEPTH

6" COMPACTED DEPTH 3/4" CR. ROCK BASE

**NOTES:**

1. METERS 1.5" AND LARGER SHALL BE SENSUS OMNI-C2 WITH AMR/AMI METER READING SYSTEM.
2. VAULT SIZING AND METER SETTER ASSEMBLY DETAILS FOR METERS LARGER THAN 2" SHALL BE PER DESIGN ENGINEER'S SPECIFICATIONS AND LCPW STANDARDS.
3. METER VAULT & LID SHALL BE PROVIDE 20K LOAD RATING OR BETTER.
4. ALL VALVES SHALL BE DOMESTIC, NRS RESILIENT SEAT GATE VALVES.
5. OWNER SHALL PROVIDE APPROVED BACKFLOW ASSEMBLY, TESTING, AND ANNUAL RECERTIFICATION PER LCPW SPECIFICATIONS AND REQUIREMENTS.
6. METER VAULTS SHALL BE PLACED AT THE BACK OF SIDEWALK & AWAY FROM VEHICULAR TRAFFIC WHENEVER POSSIBLE

## STND Water Service (1.5" and 2")

DETAIL: 511 LCPW WATER-Standard Water Service (1.5" and 2")

REVISED:  
JAN - 2024



Lincoln City

# SIDEWALK PLAN VIEW

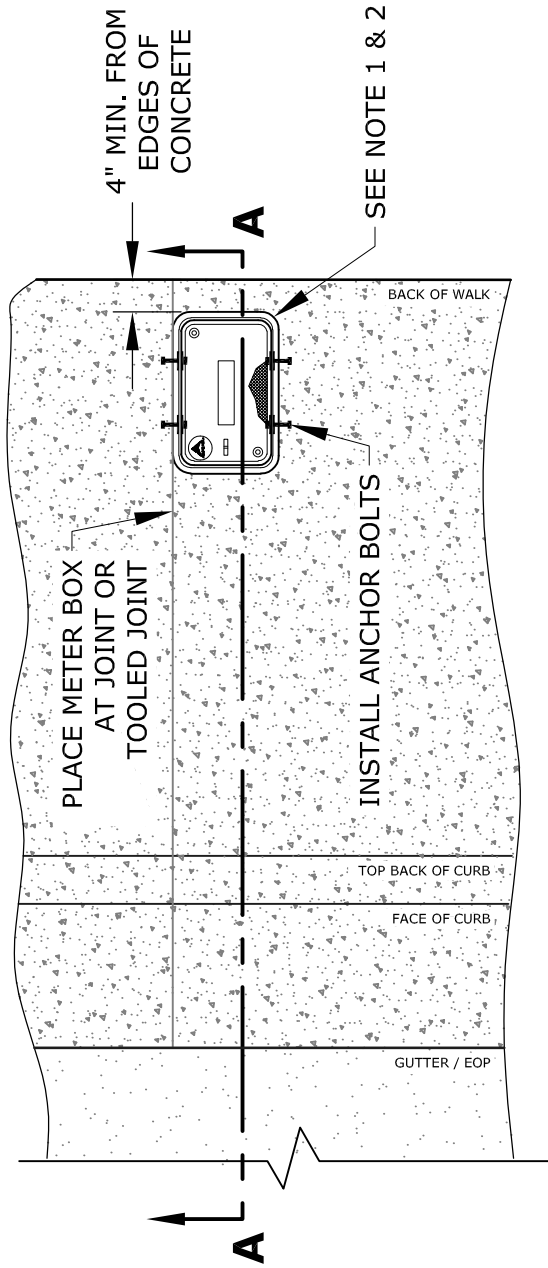

# SIDEWALK SECTION A-A

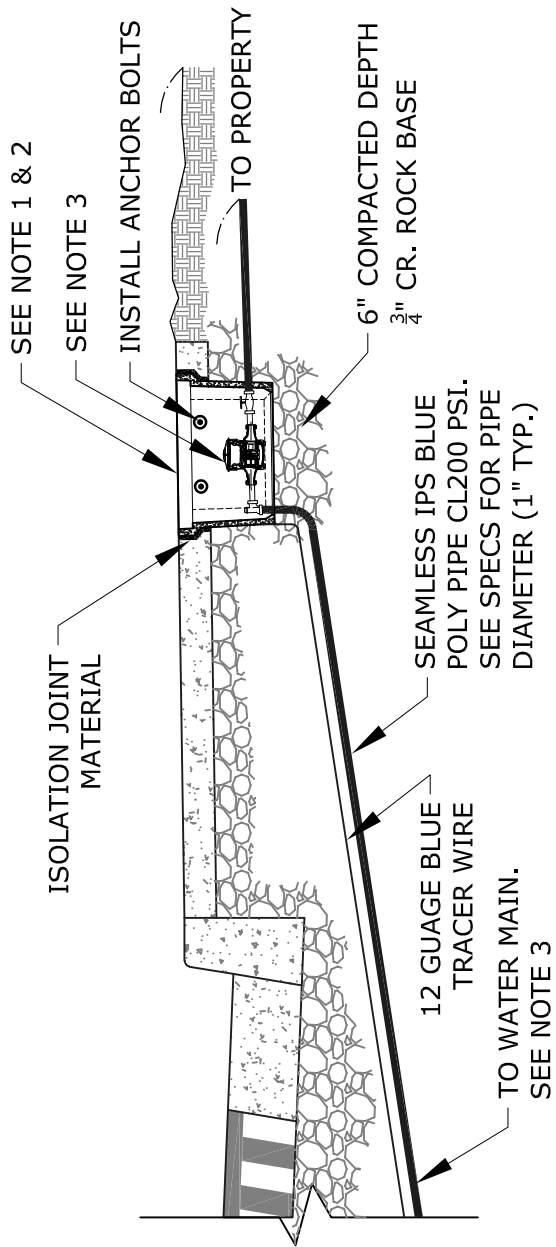

- NOTES:**
- METER VAULTS SHALL BE PLACED AT THE BACK OF SIDEWALK & AWAY FROM VEHICULAR TRAFFIC IF POSSIBLE.
  - METER VAULT & LID SHALL BE 20K LOAD RATED ARMORCAST A6000485 12"WX20"LX12"D. LARGER DIMENSIONS ARE PERMITTED.
  - SEE "510 LCPW WATER-Standard Water Service Off Sidewalk" FOR METER ASSEMBLY & CONNECTION DETAILS.

## STND Water Service ( $\frac{5}{8}$ " to 2") On Sidewalk

515-LCPW WATER-Standard Water Service On Sidewalk

REVISED:  
MAY - 2020



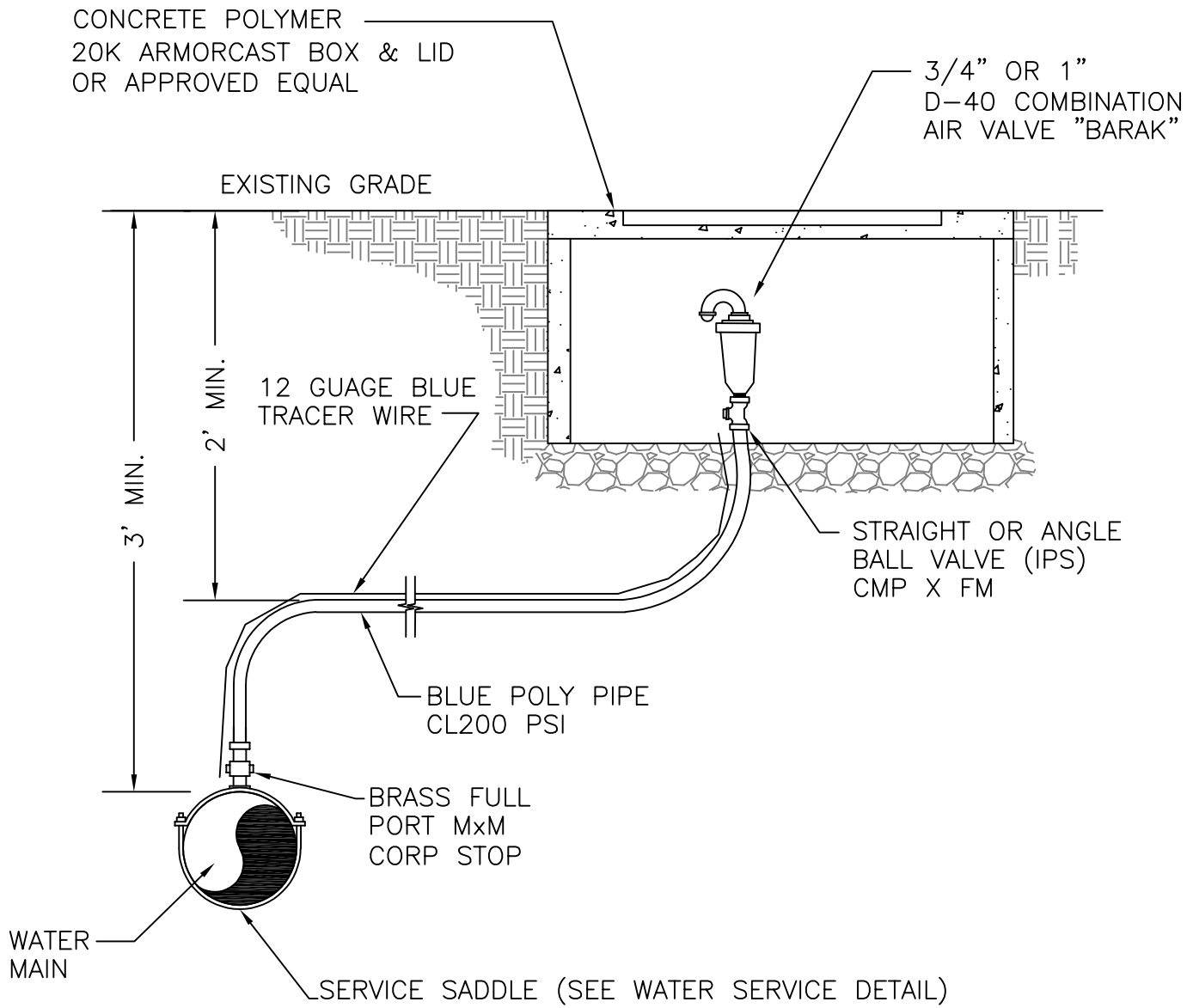

- NOTES:**
1. AIR-VAC BOXES SHALL BE PLACED AT THE BACK OF SIDEWALKS IF POSSIBLE.
  2. ALL FITTINGS SHALL BE BRASS W/ SS INSERTS
  3. FOR 2" AND LARGER AIR RELEASE & VACUUM VALVES SEE ENGINEER PROVIDED DETAIL ON APPLICABLE PLANSET.
  4. VAULT/LID SIZE SPECIFICATIONS PER LCPW WATER SERVICE DETAIL

**LCPW COMBINATION AIR RELEASE /  
AIR VACUUM ASSEMBLY - 1" & SMALLER**  
DETAIL: 500-LCPW WATER - AIR RELEASE /  
AIR VACUUM ASSEMBLY - 1" & SMALLER

REVISED:  
DEC 2021



PIPE AND HYDRANT ASSEMBLY  
TRENCH TO BE BACKFILLED  
PER CITY STANDARDS.

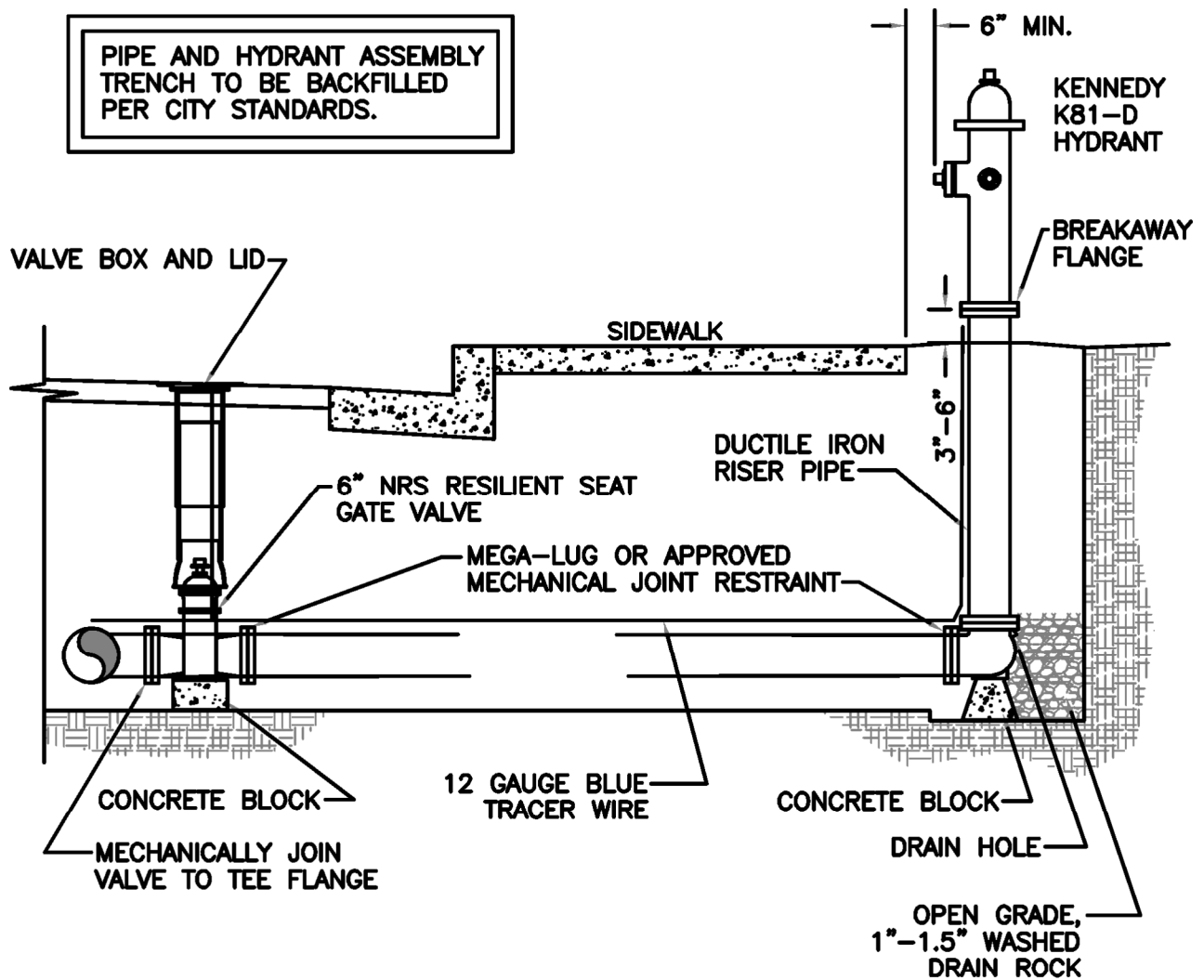

**NOTE:**

1. WHEN PIPE IS SHORTER THAN 18', NO JOINTS ALLOWED. USE MECHANICAL RETAINER GLANDS.
2. WHEN PIPE IS LONGER THAN 18' FEET, BELL RESTRAINT HARNESSES ARE REQUIRED ON ALL JOINTS.
3. THERE SHALL BE A MINIMUM OF 36" LEVEL GRADE AND CLEARANCE AROUND HYDRANT.
4. IF PLACED ADJACENT TO CURB, THERE SHALL BE 24" FROM FACE OF CURB TO HYDRANT PORT.
5. EXTENSIONS REQUIRED FOR HYDRANT SYSTEMS SHALL BE INSTALLED TO THE MANUFACTURER'S SPECIFICATIONS.
6. HYDRANTS SHALL NOT BE PLACED WITHIN 5' OF DRIVEWAYS, UTILITY POLES, OR OTHER OBSTRUCTIONS.
7. HYDRANT PUMPER PORT SHALL FACE STREET OR INTENDED DIRECTION OF ACCESS.
8. HYDRANT SHALL BE SET PLUMB IN ALL DIRECTIONS.

520-LCPW WATER-Fire Hydrant

DETAIL: 520 LCPW WATER DIST-Fire Hydrant

REVISED:  
Dec, 2019



Lincoln City

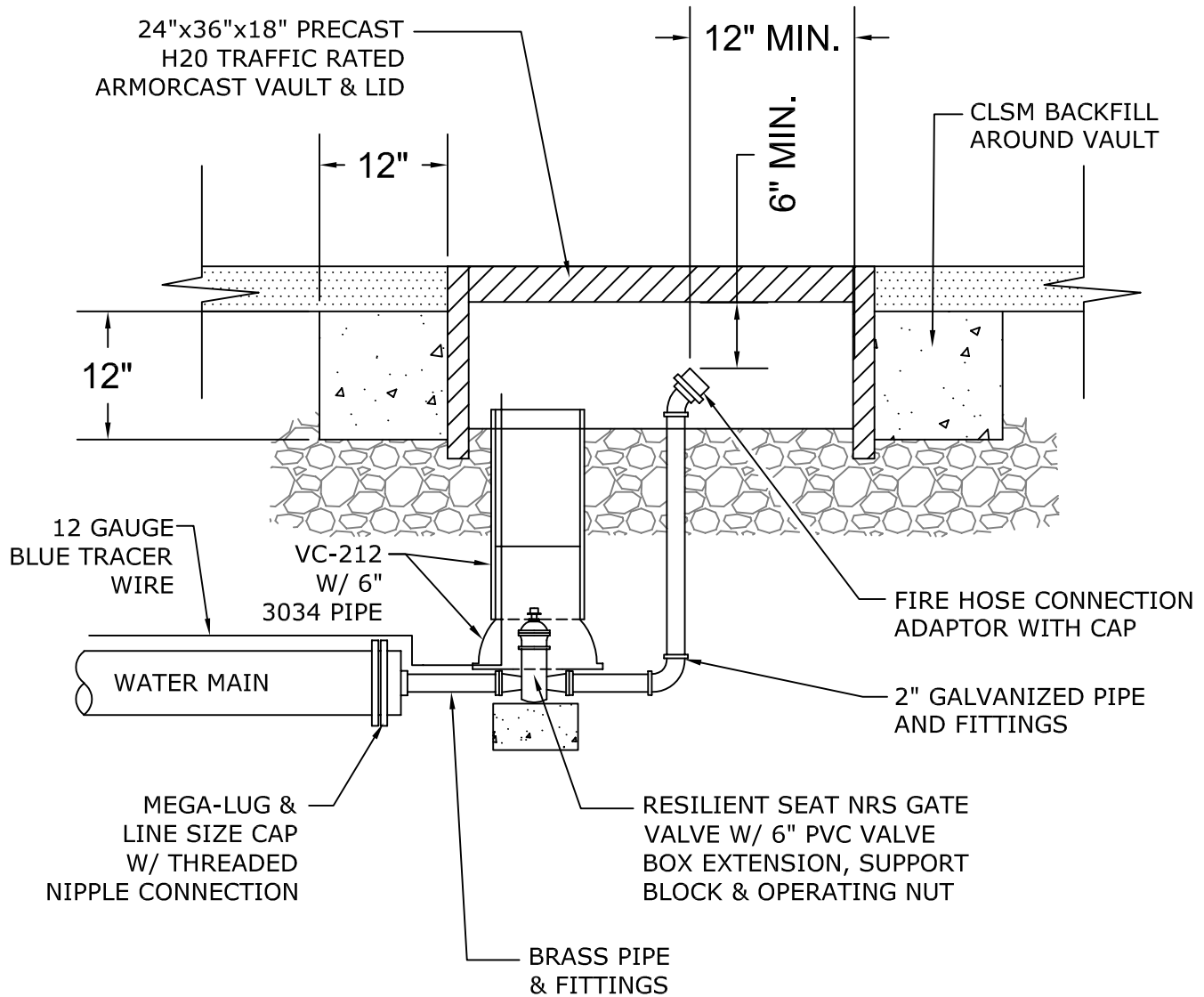

**NOTES:**

1. BELL RESTRAINT HARNESS(ES) SHALL BE REQUIRED ON MAIN A MIN. OF 36' FROM BLOW-OFF UNLESS OTHERWISE APPROVED BY LINCOLN CITY PUBLIC WORKS DEPARTMENT REPRESENTATIVE. RESTRAINT CALCULATIONS SHALL BE PREPARED BY DESIGN ENGINEER TO ENSURE ADEQUATE RESTRAINT.
2. ALL FITTINGS SHALL BE BRASS W/ SS INSERTS.

**Dead End Blow-Off Assembly**

DETAIL: 530 LCPW WATER DIST - Dead End Blow-Off Assembly

REVISED:  
Oct, 2019



Lincoln City

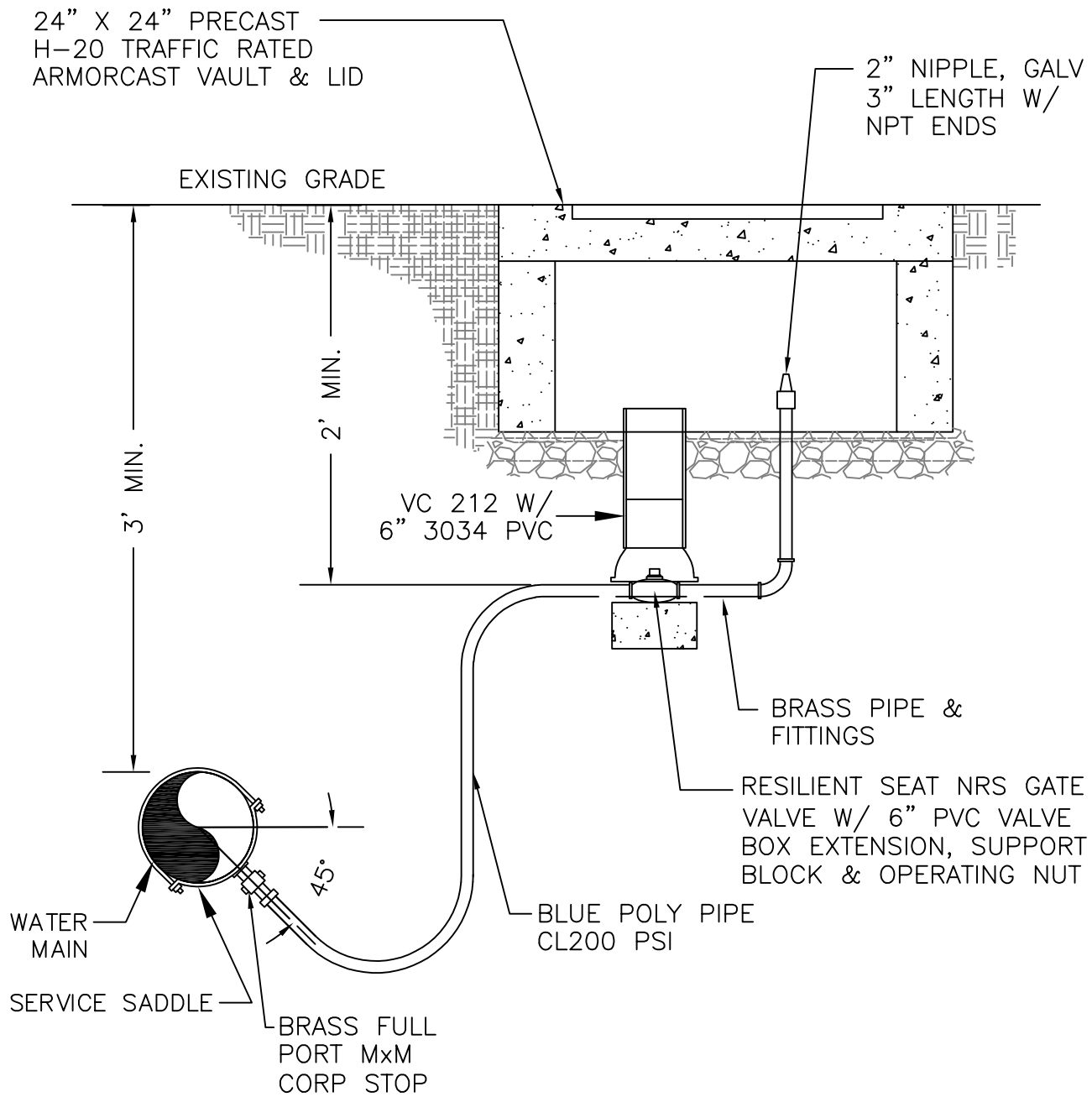

NOTES:

1. LOW POINT BLOW-OFF VAULTS SHALL BE PLACED AT THE BACK OF SIDEWALKS IF POSSIBLE.
2. ALL FITTINGS SHALL BE BRASS W/ SS INSERTS

## Combination Low Point Blow-Off Assembly

DETAIL: 540 LCPW WATER DIST - Combo  
Low Point Blow-Off Assembly

REVISED:  
Dec, 2019



Lincoln  
City

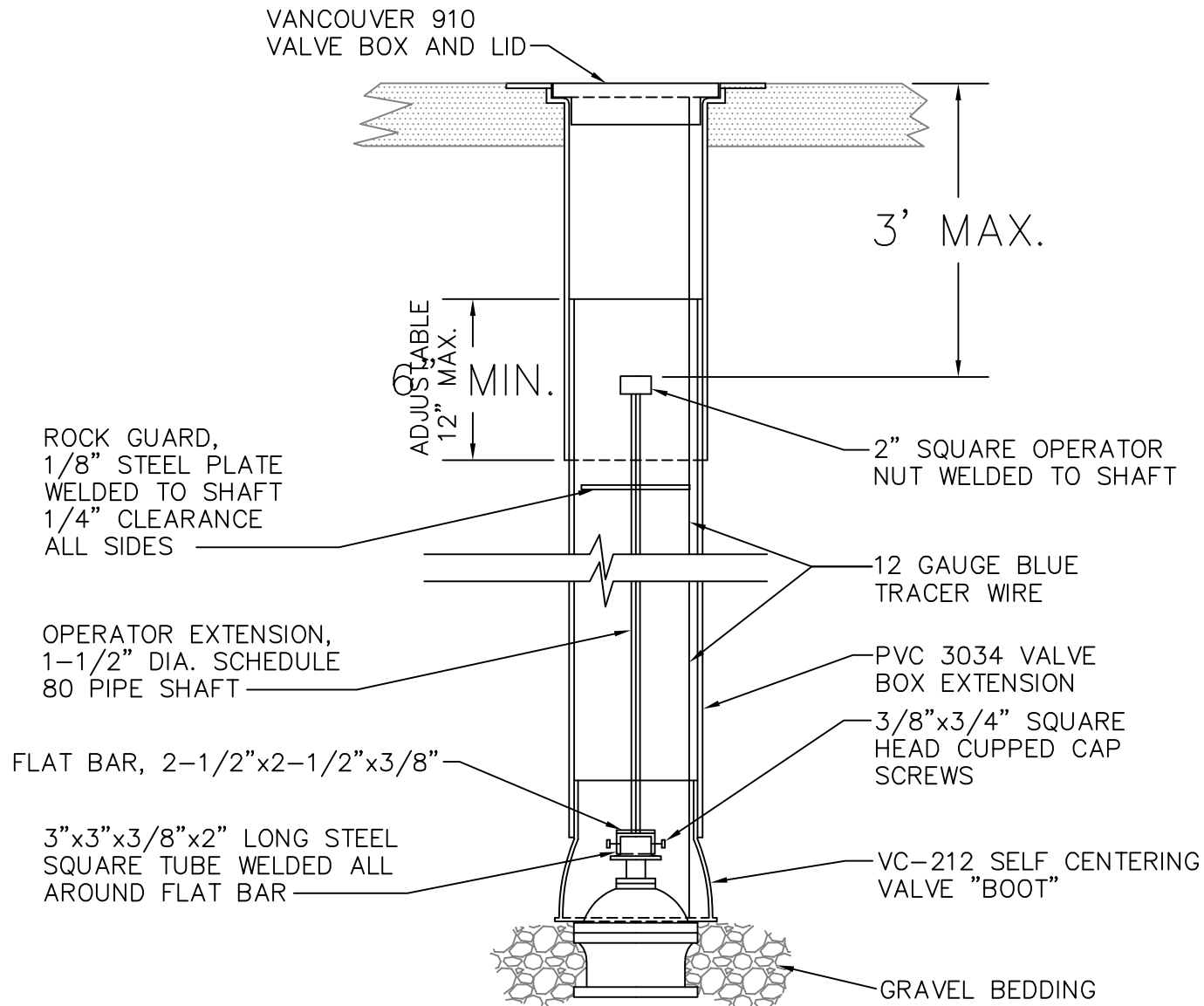

**NOTES:**

1. VALVE BOX NOT TO REST ON OPERATOR ASSEMBLY.
2. OPERATOR EXTENSION REQUIRED WHEN VALVE NUT IS DEEPER THAN 4' FROM FINISHED GRADE.
3. CENTER VALVE BOX ON AXIS OF OPERATOR NUT.
4. ALL VALVES SHALL BE SET ON PRECAST CONCRETE BLOCK.
5. WELDS SHALL BE A MINIMUM OF 1/4" ALL AROUND.
6. HOT DIP GALVANIZE OPERATOR EXTENSION AFTER MANUFACTURE.
7. FOR BUTTERFLY VALVES, MODIFICATION OF VC 212 MAY BE NECESSARY TO ENSURE THAT THE VALVE NUT IS CENTERED IN BOX & THAT THE RISER ASSEMBLY IS VERTICALLY PLUMB.

**VALVE BOX & EXTENSION ASSEMBLY**

DETAIL: 550 LCPW WATER DIST – VALVE BOX  
& EXTENSION ASSEMBLY

REVISED:  
Dec, 2021



Lincoln  
City

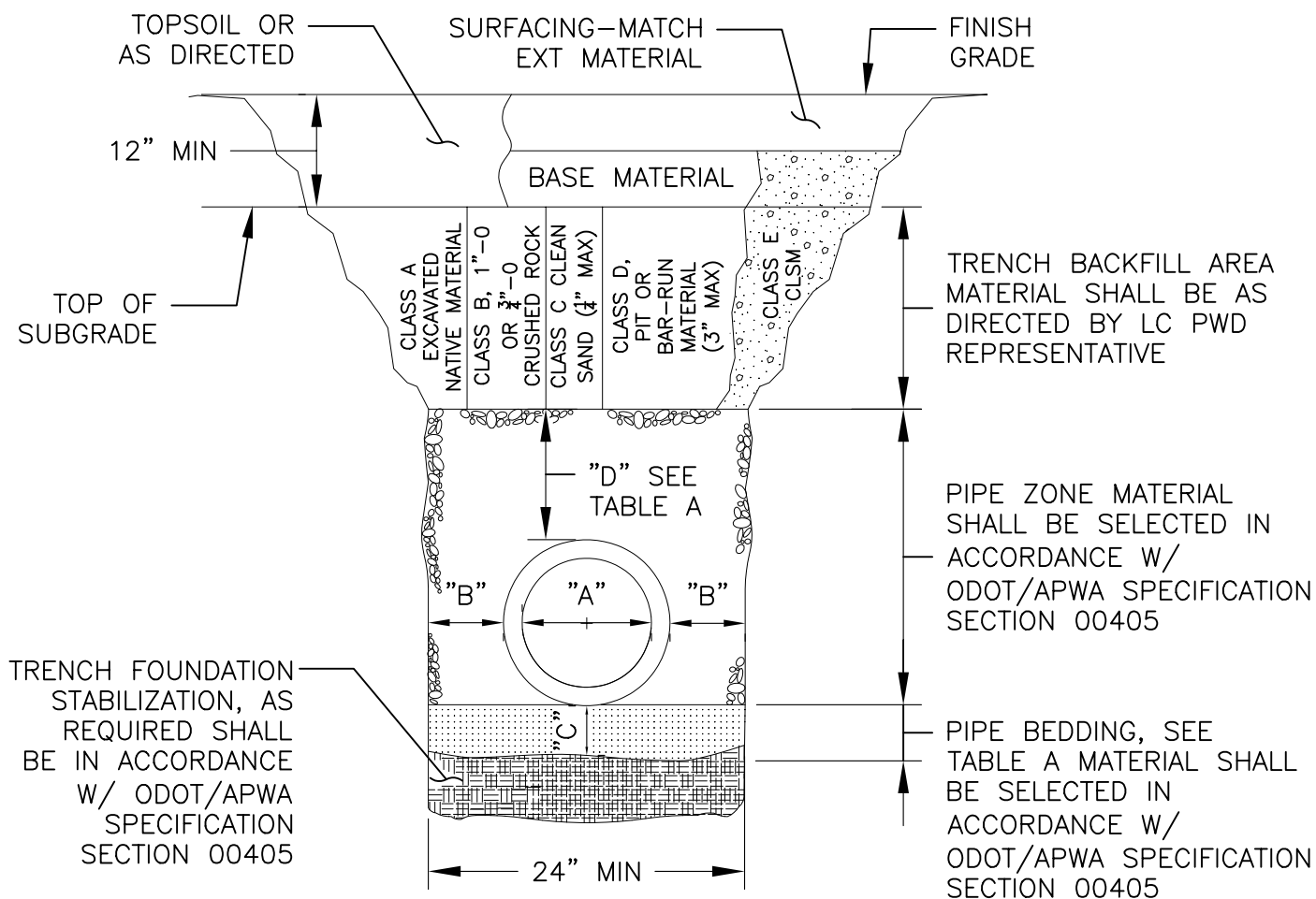

**NOTES:**

- "A" = NOMINAL PIPE DIAMETER.
- SURFACING OF PAVED AREAS SHALL COMPLY W/ OREGON STANDARD DRAWING RD302.
- FOR PIPE INSTALLATION IN EMBANKMENT AREAS WHERE THE TRENCH METHOD WILL NOT BE USED & THE PIPE IS GREATER THAN OR EQUAL TO 36" DIAMETER, INCREASE DIMENSION "B" TO NOMINAL PIPE DIAMETER.
- PIPES OVER 72" DIAMETER ARE STRUCTURES, & ARE NOT APPLICABLE TO THIS DRAWING.
- INSTALL TRACER WIRE ALONG CROWN OF PIPE.
- THE PROPERTY OWNER SHALL BE RESPONSIBLE FOR THE CONDITION OF THE STREET REPAIR FOR A PERIOD OF 1 YEAR AFTER RECEIVING FINAL PROJECT APPROVAL/ACCEPTANCE.
- MATERIAL IN THE PIPE ZONE SHALL BE COMPACTED BY VIBRATORY PLATE OR JUMPING JACK PER CURRENT APWA SPECIFICATIONS.
- CONTRACTOR IS RESPONSIBLE FOR PLATING TRENCH WHILE CLSM BACKFILL MATERIAL CURES.
- TEE CUT FOR ASPHALT PATCHING WILL BE MADE AFTER TRENCH EXCAVATION & BACKFILL. EDGES OF CUT SHALL BE FREE OF ANY SPALLING, BROKEN EDGES, CRACKS, UPLIFT & UNDERMINED SUBGRADE.
- IF HOT MIX ASPHALT IS UNAVAILABLE, THE CONTRACTOR SHALL USE COLD MIX AS A TEMPORARY PATCH UNTIL HOT MIX IS AVAILABLE FOR PERMANENT REPAIRS.
- ALL EDGES OF THE PERMANENT PATCHING SHALL BE TACK & SAND SEALED.
- PATCHING OF THE TRENCH SHALL BE COMPLETED NO LATER THAN 2 DAYS AFTER INSTALLATION INSPECTION. THE CITY RESERVES THE RIGHT TO MAKE REPAIRS & BILL THE CONTRACTOR ACCORDINGLY IF PATCHING HAS NOT BEEN COMPLETED AS REQUIRED.
- THE ASPHALT PATCH SHALL BE COMPACTED TO A MIN. OF 92% DENSITY, W/ A MAX. SURFACE SMOOTHNESS DEVIATION OF 1/4" PER ODOT/APWA SPECIFICATION 00745.70(b).
- FOR MULTIPLE PIPE INSTALLATIONS SEE PIPE CLEARANCES STANDARD DETAIL.
- THE CONTRACTOR SHALL SCHEDULE INSPECTIONS A MIN. OF 24-HOURS IN ADVANCE W/ LINCOLN CITY PUBLIC WORKS DEPARTMENT AT 541( 996)-2154.

TABLE A

"A" (in)	"B" (in)	"C" (in)	"D" (in)
4	10	4	8
6	10	4	8
8	10	6	10
10	10	6	10
12	12	6	10
15	12	6	10
18	16	6	12
21	16	6	12
24	18	6	12
30	18	6	12
36	24	6	14
42	24	6	14
48	24	6	14
54	24	6	14
60	24	6	14
66	24	6	14
72	24	6	14

**400-LCPW STREETS-Trench Cut**

DETAIL: 400 LCPW STREETS-Trench Cut

REVISED:  
MAY, 2020



**SIDEWALK MAILBOX AND OBSTRUCTIONS**

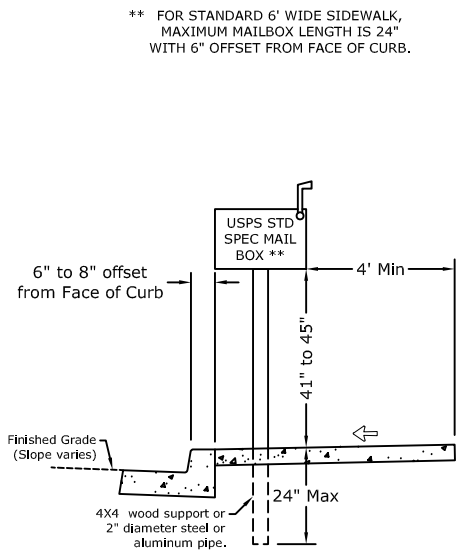

**STANDARD USPS MAILBOX ON SIDEWALK**

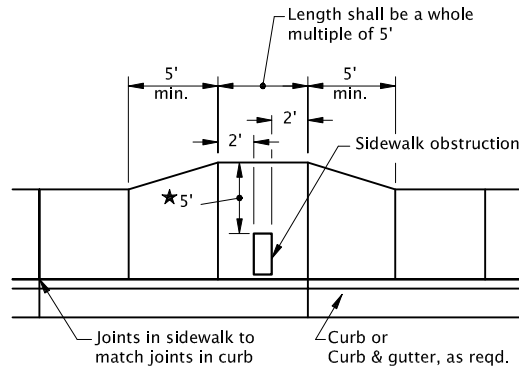

★ When site constraints prohibit a 5' passage, the Engineer may direct this to be reduced, but no less than 4'.

**REQUIRED SIDEWALK WIDENING AROUND OBSTRUCTIONS**

← Slope 1.5% max. (Max. 2.0% finished surface slope) (Normal sidewalk cross slope)

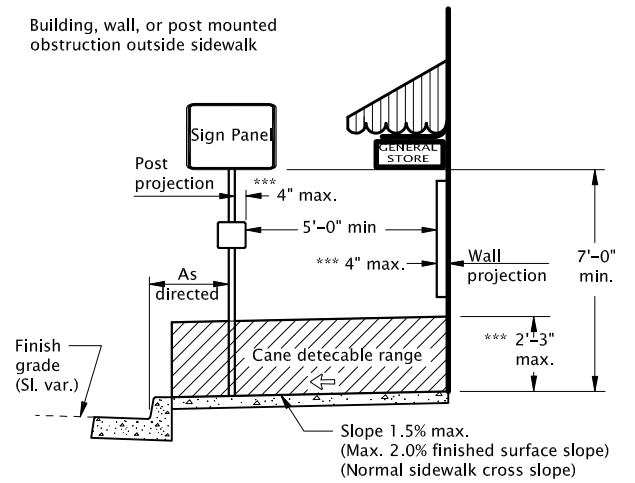

\*\*\* Objects with base below 2'-3" may protrude any distance as long as the 5' circulation path is maintained. When an object with a base higher than 2'-3" protrudes further than 4" provide a detection below protrusion to delineate edge.

**CLEAR CIRCULATION PATH**



# TYPICAL LINCOLN CITY SIDEWALK CROSS SECTION

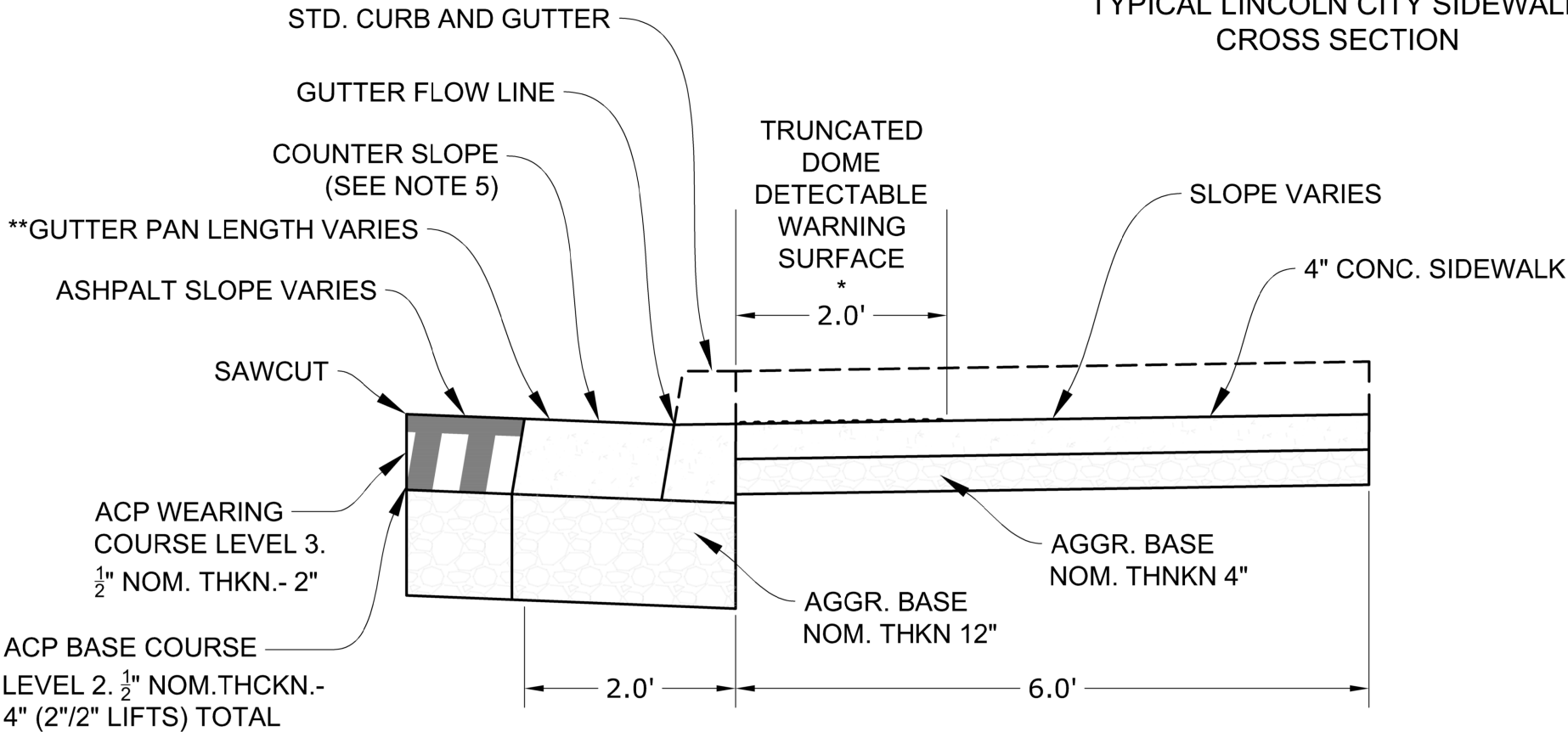

**GENERAL NOTES:**

- \* 1. SEE ODOT.STD.DWG.RD700 FOR CURBS. SEE ODOT.STD.DWG.RD720 FOR CURBS & RD755 FOR SIDEWALKS AND RAMPS.
- 2. TOOLED JOINTS ARE REQUIRED AT ALL SIDEWALK RAMP SLOPE BREAK LINES.
- 3. PLACE TRUNCATED DOME DETECTABLE WARNING (TDDW) SURFACE IN THE LOWER 2' ADJACENT TO TRAFFIC AT THROAT OF RAMP ONLY. FOR DETAILS NOT SHOWN, SEE ODOT.STD.DWG.RD759.
- 4. FOR SPECIFIC GRADE INFORMATION, GRADE & LAYOUT SHEETS.
- \*\* 5. GUTTER PAN SLOPE IS 4% UNLESS OTHERWISE NOTED. IF CHANGE IN GRADE BETWEEN RAMP AND STREET COUNTER SLOPE IS GREATER THAN OR EQUAL TO 11% ADD A 2' LEVEL STRIP. SEE GRADE & LAYOUT SHEETS FOR GUTTER PAN WIDTH CALLOUT.
- 6. SAWCUT WIDTH VARIES TO ACHIEVE THE COUNTER-SLOPES LISTED IN THE CURB RAMP DETAIL SHEETS.

<p><b>LCPW STREETS STANDARD DETAIL 420</b></p> <p>TYPICAL LINCOLN CITY SIDEWALK CROSS SECTION</p>	
<p><b>DRAWN BY: A. B.</b> <b>CHECKED BY: T.C.</b></p> <p>REVISED: 9/30/2022</p>	<p><b>LINCOLN CITY PUBLIC WORKS</b> 801 S.W. HWY 101 P.O. BOX 50 LINCOLN CITY, OREGON 97367 PHONE: (541) 996-2154 FAX: (541) 994-4881 <a href="http://www.lincolncity.org">www.lincolncity.org</a></p>

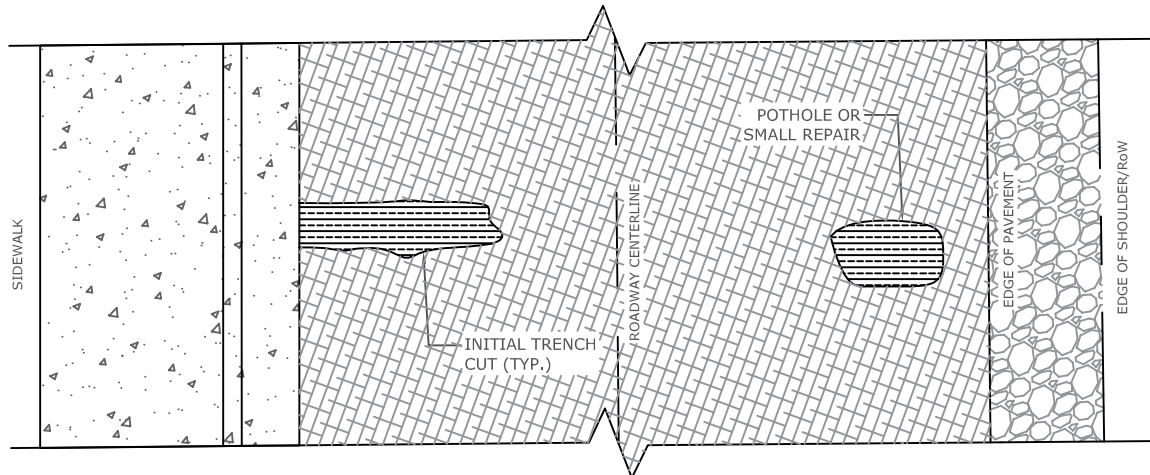

CONDITIONS BEFORE PATCHING / REPAIR

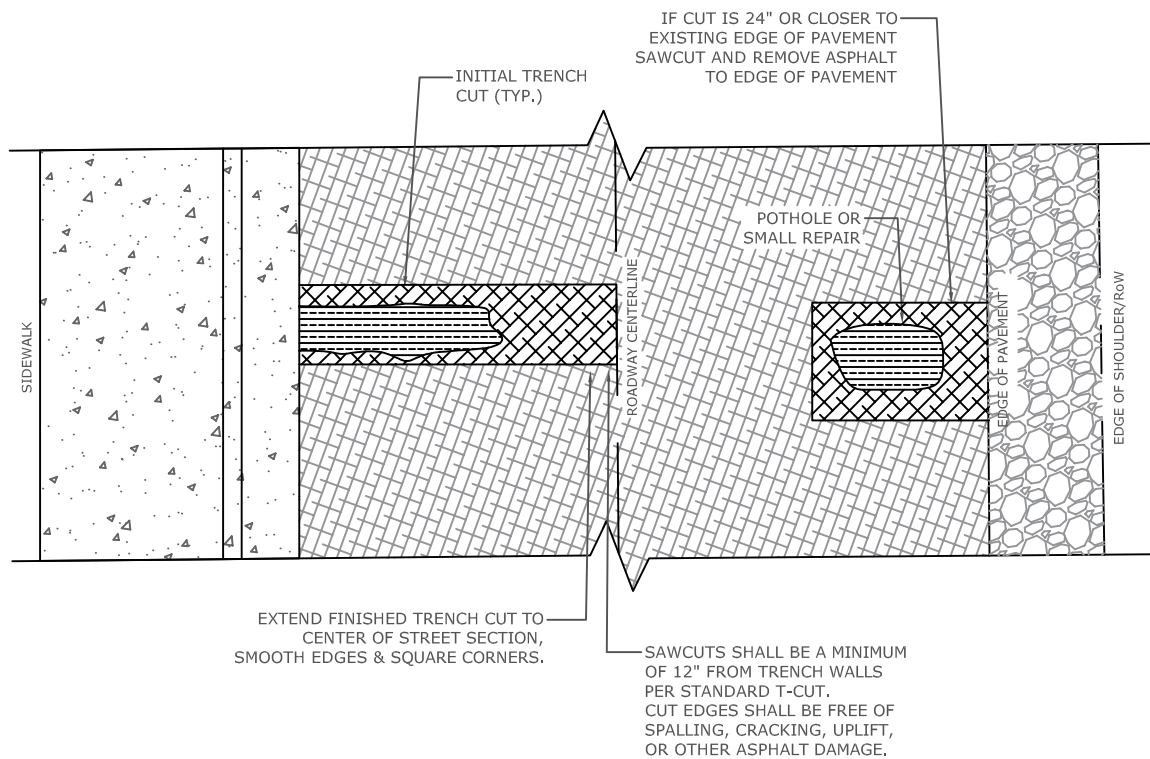

CONDITIONS AFTER PATCHING / REPAIR

NOTES:

1. AGGREGATE BASE BACKFILL SHALL BE COMPACTED TO 95% COMPACTION.
2. ALL PAVEMENT JOINTS SHALL BE SEALED PER APWA/ODOT STANDARD SPECIFICATIONS.
3. ASPHALT SHALL BE PLACED & COMPACTED PER APWA/ODOT STANDARD SPECIFICATIONS.
4. ASPHALT MIX DESIGN SHALL ADHERE TO APWA/ODOT STANDARDS SPECIFICATIONS, TYPE II HMAC UNLESS OTHERWISE SPECIFIED & APPROVED.
5. ALL CONTROL OF WORK & RESULTING PRODUCT SHALL ADHERE TO LCPW RIGHT-OF-WAY PERMIT STANDARD SPECIFICATIONS

STREET PATCH REPAIR

DETAIL: 430 LCPW STREETS & ADA - STREET PATCH REPAIR

REVISED:  
DEC 2021

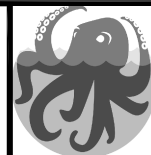

Lincoln City

## ISOMETRIC

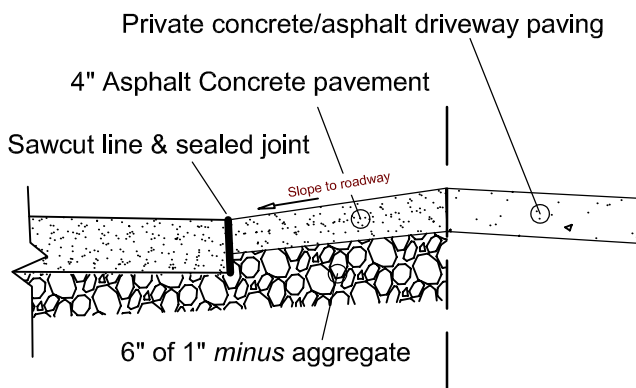
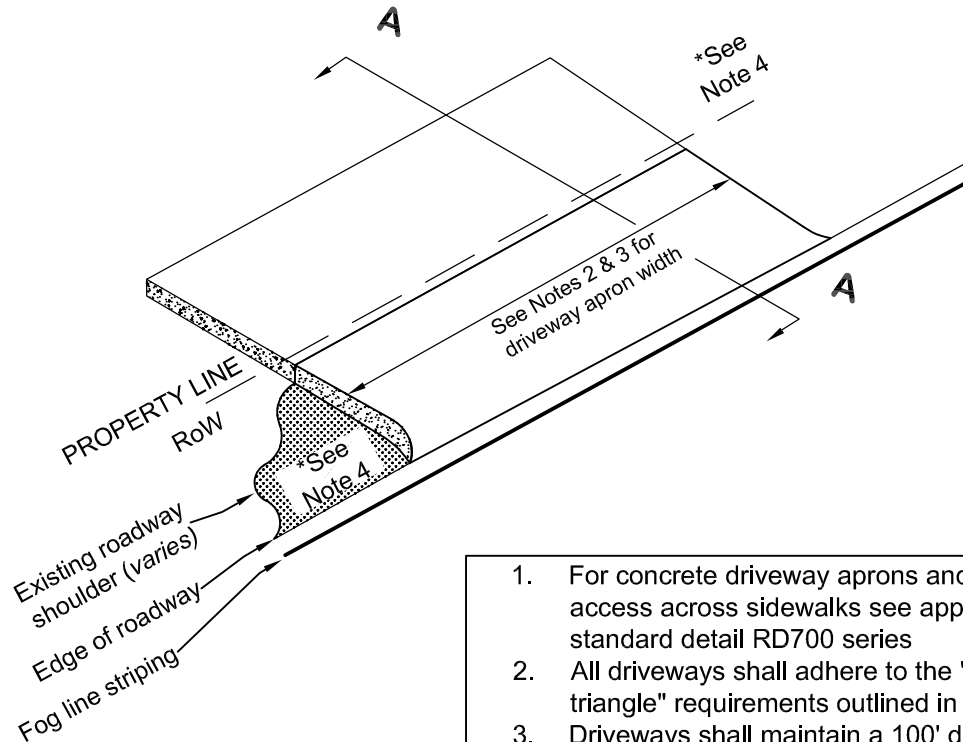

**CROSS SECTION A-A**

1. For concrete driveway aprons and driveway access across sidewalks see applicable ODOT standard detail RD700 series
2. All driveways shall adhere to the "Clear vision triangle" requirements outlined in LCMC 17.52.060
3. Driveways shall maintain a 100' distance from intersections OR the maximum distance possible. - For corner lots, driveways shall be designed to access via the lower traffic roadway.
4. Meet existing asphalt pavement at **clean edge**. Any spalling is to be sawcut & removed in a straight line. Sand & tack shall be used to seal all asphalt seams.
5. Minimum driveway apron width shall be 10' for one-way access and 20' feet for two-way access per LCPW 12.28.200
6. Maximum driveway apron width shall be 12' for one-way access and 24' feet for two way access per LCPW 12.28.200
7. Additional delineation may be required at the property line dependant on surfacing/landscaping adjacent to the driveway.
8. The owner or their agent is responsible for overall drainage design of the driveway & shall design driveways to keep roadway water along the existing flowline. Additional drainage requirements may be specified by LCPW.

## 440-LCPW STREETS-Residential Driveways

DETAIL: 440 LCPW STREETS-Residential Driveways

REVISED:  
Dec 2021



Lincoln  
City

**NOTES:**

1. WASHOUT FACILITIES SHALL BE MAINTAINED TO PROVIDE ADEQUATE HOLDING CAPACITY WITH A MINIMUM FREEBOARD OF 12 INCHES.
2. WASHOUT FACILITIES MUST BE CLEANED, OR NEW FACILITIES MUST BE CONSTRUCTED AND READY FOR USE ONCE THE WASHOUT IS 75% FULL.
3. IF THE WASHOUT IS NEARING CAPACITY, VACUUM AND DISPOSE OF THE WASTE MATERIAL IN AN APPROVED MANNER.
4. TEMPORARY CONCRETE WASHOUT FACILITIES SHALL BE LOCATED A MINIMUM OF 50 FT FROM SENSITIVE AREAS INCLUDING OPEN DRAINAGE FACILITIES AND WATERSOURCES.
5. CONCRETE WASHOUT FACILITIES SHALL BE CONSTRUCTED AND MAINTAINED IN SUFFICIENT QUANTITY AND SIZE TO CONTAIN ALL LIQUID AND CONCRETE WASTE GENERATED BY WASHOUT OPERATIONS.
6. INSTALL CONCRETE WASHOUT SIGN WITHIN 30 FEET OF TEMPORARY CONCRETE WASHOUT FACILITY.
7. TEMPORARY CONCRETE WASHOUTS MAY BE A PREFABRICATED CONTAINER THAT IS PORTABLE AND REUSABLE.

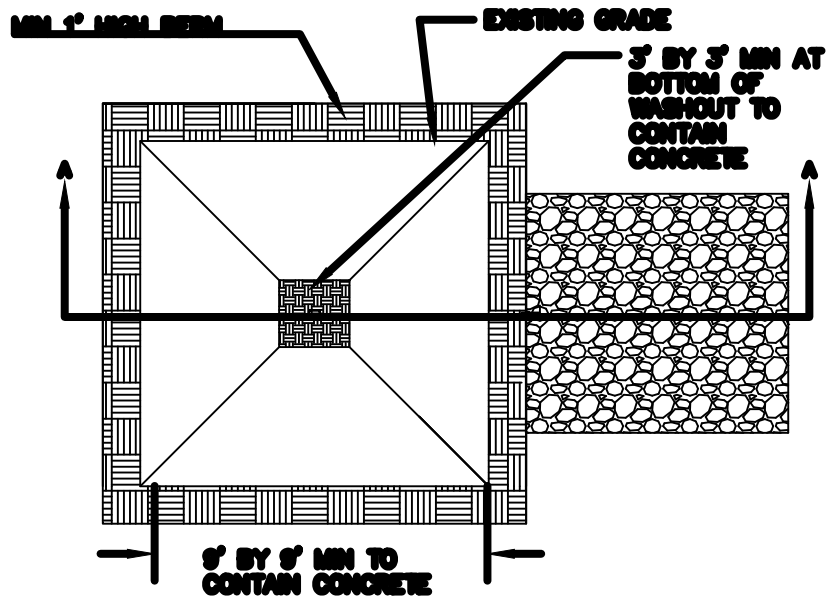

**PLAN  
NOT TO SCALE**

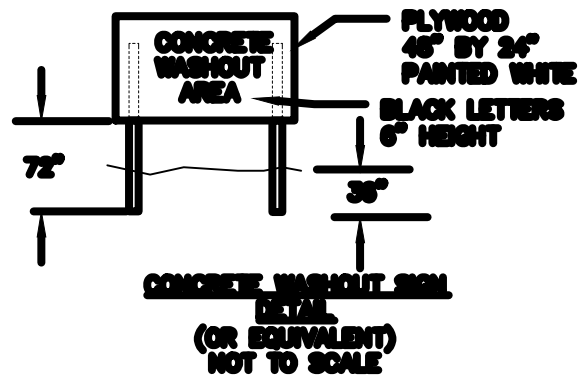

**CONCRETE WASHOUT SIGN  
DETAIL  
(OR EQUIVALENT)  
NOT TO SCALE**

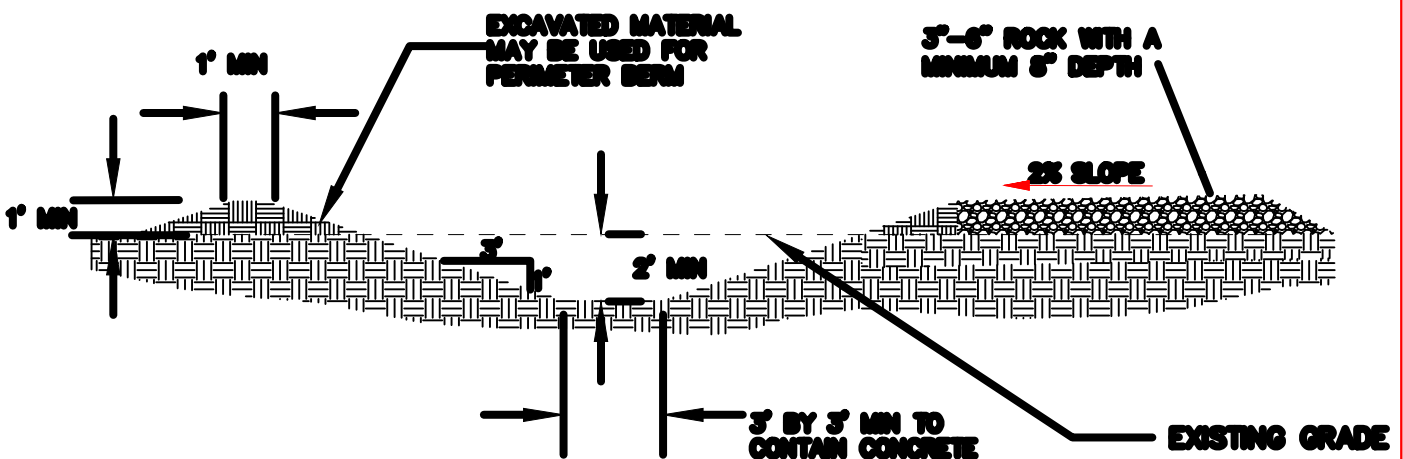

**SECTION A-A  
NOT TO SCALE**

CONCRETE WASHOUT

